

RESEARCH REPORT 1732-1

RE-EVALUATION OF RAMP DESIGN SPEED
CRITERIA: REVIEW OF PRACTICE AND
DATA COLLECTION PLAN

Michael Hunter and Randy B. Machemehl

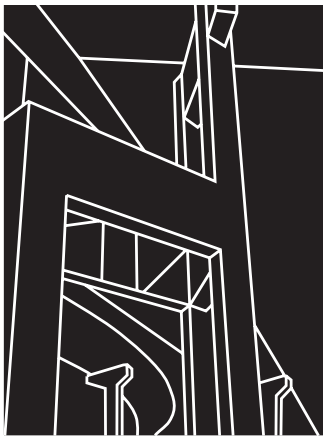

CENTER FOR TRANSPORTATION RESEARCH
BUREAU OF ENGINEERING RESEARCH
THE UNIVERSITY OF TEXAS AT AUSTIN

APRIL 1997

1. Report No. FHWA/TX-98/1732-1	2. Government Accession No.	3. Recipient's Catalog No.	
4. Title and Subtitle REEVALUATION OF RAMP DESIGN SPEED CRITERIA: REVIEW OF PRACTICE AND DATA COLLECTION PLAN		5. Report Date April 1997	
7. Author(s) Michael Hunter and Randy Machemehl		6. Performing Organization Code	
		8. Performing Organization Report No. 1732-1	
9. Performing Organization Name and Address Center for Transportation Research The University of Texas at Austin 3208 Red River, Suite 200 Austin, TX 78705-2650		10. Work Unit No. (TRAIS)	
		11. Contract or Grant No. 0-1732	
12. Sponsoring Agency Name and Address Texas Department of Transportation Research and Technology Transfer Section/Construction Division P.O. Box 5080 Austin, TX 78763-5080		13. Type of Report and Period Covered Research Report (9/1/98 to 8/31/99)	
		14. Sponsoring Agency Code	
15. Supplementary Notes Project conducted in cooperation with the Federal Highway Administration.			
16. Abstract <p>Freeway ramp design speed criteria contained in current American Association of Highway and Transportation Official (AASHTO) and Texas Department of Transportation (TxDOT) design policies have been traced through roughly 50 years of technical literature. The evolution of design speed criteria has been documented and technical rational leading to periodic changes has been included. TxDOT ramp design speed criteria are, essentially, the AASHTO criteria. The origins of driver acceleration and deceleration rates, which are built into the AASHTO criteria, are experimental studies performed during the late thirties. Several studies have raised questions about the appropriateness of the AASHTO minimum allowable ramp design speed, which is 50 percent of the freeway design speed. Questions have also been raised about the adequacy of high-speed ramp lengths designed by AASHTO criteria. A conceptual data collection plan has been designed to provide information that will answer questions regarding current criteria. Additionally, a nationwide survey of ramp design agencies indicates that (1) there is a variety of different design policies; (2) most designers have concern for entrance ramps, as opposed to exits; and (3) safety is the most commonly used evaluation measure.</p>			
17. Key Words: Design speed, ramp speed, interchange and ramp types, accidents, entrance ramps, exit ramps, sight distance, deceleration lanes, acceleration lanes, ramp design speed criteria		18. Distribution Statement No restrictions. This document is available to the public through the National Technical Information Service, Springfield, Virginia 22161.	
19. Security Classif. (of report) Unclassified	20. Security Classif. (of this page) Unclassified	21. No. of pages 104	22. Price

**RE-EVALUATION OF RAMP DESIGN SPEED CRITERIA: REVIEW OF
PRACTICE AND DATA COLLECTION PLAN**

by

Michael Hunter

and

Randy B. Machemehl

Research Report Number 1732-1

Research Project 0-1732

Re-evaluation of Ramp Design Speed Criteria

Conducted for the

TEXAS DEPARTMENT OF TRANSPORTATION

in cooperation with the

**U.S. DEPARTMENT OF TRANSPORTATION
FEDERAL HIGHWAY ADMINISTRATION**

by the

CENTER FOR TRANSPORTATION RESEARCH
Bureau of Engineering Research
THE UNIVERSITY OF TEXAS AT AUSTIN

April 1997

IMPLEMENTATION RECOMMENDATIONS

Current freeway ramp design speed criteria have evolved through practice, research, and policy actions over several decades. A first step toward re-evaluating these criteria must include an examination of this evolutionary process, and that examination is a primary part of this report. The review contained herein serves as a foundation for the research efforts that will follow, as well as the policy recommendations that will be developed. Based upon the review, this document also provides a conceptual primary data collection plan that will guide future research tasks.

ACKNOWLEDGMENTS

The authors acknowledge the support of TxDOT project director E. Penstock (DES).

Prepared in cooperation with the Texas Department of Transportation and the
U.S. Department of Transportation, Federal Highway Administration

DISCLAIMERS

The contents of this report reflect the views of the authors, who are responsible for the facts and the accuracy of the data presented herein. The contents do not necessarily reflect the official views or policies of the Federal Highway Administration or the Texas Department of Transportation. This report does not constitute a standard, specification, or regulation.

There was no invention or discovery conceived or first actually reduced to practice in the course of or under this contract, including any art, method, process, machine, manufacture, design or composition of matter, or any new and useful improvement thereof, or any variety of plant, which is or may be patentable under the patent laws of the United State of America or any foreign country.

NOT INTENDED FOR CONSTRUCTION,
BIDDING, OR PERMIT PURPOSES

Randy B. Machemehl, P.E. (Texas No. 41921)

Research Supervisor

TABLE OF CONTENTS

CHAPTER 1. LITERATURE REVIEW	1
Introduction	1
Design Basics	1
Definition of Design Speed	2
Safe Stopping Sight Distance	2
Horizontal Curves	5
Vertical Curves	11
Interchanges and Ramp Types	16
Interchanges	16
Ramp Types	18
Ramp Design	21
Design Speed	21
Superelevation and Side Friction Factor	22
Sight Distance	26
Grades	26
Other Ramp Design Issues	27
Ramp Terminals	27
TxDOT Speed-Change Lane Design	33
Entrance Ramps	33
Exit Ramps	35
Other TxDOT Ramp Operations Issues	42
Development of Current Ramp Design Standards	42
Design Speed	42
Guide Values for Ramp Design Speed	43
Taper Section	47
Deceleration Lanes	48
Acceleration Lanes	52
Acceleration and Deceleration Rates	56
Accidents	65
Results from Other Models	69
Summary	72

CHAPTER 2. SURVEY OF DESIGN PRACTICE	75
Summary	80
CHAPTER 3. DATA COLLECTION PLAN	87
Data Collection Concepts	87
Site Selection Considerations	89
Dependent Variables	89
Accident History	89
Special Loop Ramp Considerations	90
Summary	90
REFERENCES	91

SUMMARY

Freeway ramp design speed criteria contained in current American Association of Highway and Transportation Official (AASHTO) and Texas Department of Transportation (TxDOT) design policies have been traced through roughly 50 years of technical literature. The evolution of design speed criteria has been documented and a technical rationale leading to periodic changes has been included. TxDOT ramp design speed criteria are, essentially, the AASHTO criteria. The origins of driver acceleration and deceleration rates, which are built into the AASHTO criteria, are experimental studies performed during the late thirties. Several studies have raised questions about the appropriateness of the AASHTO minimum allowable ramp design speed, which is 50 percent of the freeway design speed. Questions have also been raised about the adequacy of high-speed ramp lengths designed by AASHTO criteria. A conceptual data collection plan has been designed to provide information that will answer questions regarding current criteria. Additionally, a nationwide survey of ramp design agencies indicates that 1) there is a variety of different design policies, 2) most designers have concern for entrance ramps, as opposed to exits, and 3) safety is the most commonly used evaluation measure.

CHAPTER 1. LITERATURE REVIEW

INTRODUCTION

This chapter reviews and compares ramp design as practiced currently by the Texas Department of Transportation (TxDOT) and by the American Association of State Highway and Transportation Officials (AASHTO). In addition, it seeks to develop a concise understanding of the assumptions that could potentially lead to limitations and deficiencies in current design practices. Included as part of this effort is a review of the research that has provided the foundation for these current designs.

The review of current standards is based primarily on the *Highway Design Division Operations and Procedures Manual*, issued by the Texas State Department of Highways and Public Transportation (now TxDOT), and AASHTO's 1990 (and 1994) publication, *A Policy on Geometric Design of Highways and Streets*. The standards within the *Operations and Procedures Manual* are generally considered by TxDOT to be the lowest acceptable design limits. Accordingly, a higher than minimum design standard should be utilized wherever feasible. The TxDOT guide is not to be considered inflexible and is not a substitute for engineering judgment. It may be possible to deviate from standards with approval from governing authorities.

AASHTO's *A Policy on Geometric Design of Highways and Streets* (1990) will be referred to throughout this text as the AASHTO manual (or simply AASHTO). The official position of TxDOT regarding AASHTO, according to the *Operations and Procedures Manual*, is as follows:

The American Association of State Highway and Transportation Officials (AASHTO) has established various standards, policies, guides, etc., relating to highway practice. These are approved references to be used in conjunction with this Manual; however, since AASHTO policies and guidelines represent nationwide guidelines which do not always satisfy Texas conditions, the instructions in this Manual shall take precedence over AASHTO standards.

When necessary for a particular project, geometric layouts are submitted by TxDOT to the Federal Highway Administration, or FHWA (federal-aid projects), for approval and coordination.

DESIGN BASICS

To review the effect of ramp and freeway design speed on the physical layout of a ramp it is first necessary to review several design concepts. Accordingly, before discussing current TxDOT and AASHTO ramp design practices, the following concepts are presented: design speed, safe stopping sight distance, horizontal curvature, and vertical curvature. While the concepts discussed apply to design in general, some of the minimums and

assumptions presented in the following discussion pertain to “open road conditions.” In general these minimums also apply to ramp design, but any differences will be highlighted in the ramp design section.

Definition of Design Speed

According to the *Operations and Procedures Manual*:

Design speed is the maximum safe speed that can be maintained over a specified section of highway when the design features of the highway govern. All facilities should be designed with all elements in balance, consistent with an appropriate design speed. Design elements such as sight distance, vertical and horizontal alignment, lane widths, roadside clearance, superelevation, etc. are influenced by design speed. It is therefore important that an appropriate design speed be selected.

Design speed is generally indicative of the type of operation expected on a facility: Freeways typically have design speeds ranging between 97 and 128 km/h, whereas lower-level facilities such as arterials and collectors have lower design speeds, say 48 to 97 km/h. The direct influence of design speed on the geometric characteristics of a facility will be seen throughout this report.

Safe Stopping Sight Distance

One of the most basic impacts of design speed on facility geometrics may be seen in the requirements for safe stopping sight distance — that is, the minimum visible roadway distance required for a driver to stop his/her vehicle. Sight distance should provide the driver sufficient time to gather information, process it, perform the required control actions, factor in the vehicle’s response time, and evaluate the appropriateness of possible responses (20). Stopping sight distance is typically considered a sum of two distances, namely, the distance traveled from the instant the driver sees the object to the instant the driver applies the brakes (reaction time), including the distance the vehicle travels during braking.

The first portion of the stopping sight distance is commonly referred to as the PIJR (perception, identify, judgment, and reaction) or PIEV (perception, identify, evolution, volition) time (2). Simply stated, this is the time required to see the object, identify the need to stop, and then physically apply the brakes. During this time the vehicle travels at a constant speed a distance of:

$$D_p = (0.278)(t)(v) \tag{1.1}$$

where

- v = initial speed,
- t = PIJR time, and
- d = distance (meters).

Various studies conducted to measure the PIJR time for individuals have determined that an individual's PIJR time depends on many factors, including time of day, age of the individual, driver attention, and the complexity of the situation. A reaction time of 2.5 seconds has been adopted by AASHTO (1) and is subsequently utilized in TxDOT's *Operations and Procedures Manual* (5) in the calculation of stopping sight distances. This time is based on research in which 90 percent of the drivers studied had PIJR times that fell below 2.5 seconds (1, 4, and 24).

The second portion of the required stopping sight distance is the braking distance, which is determined as follows (3):

$$d_b = \frac{v^2 - u^2}{254(f \pm g)} \quad (1.2)$$

where

- d_b = braking distance (meters),
- v = initial speed of vehicle (km/h),
- u = final speed of vehicle (km/h),
- f = coefficient of forward rolling or skidding friction, and
- g = grade, expressed as a decimal.

For stopping sight distance, u , the final speed will equal 0. As with the PIJR time, many studies have been conducted to measure the coefficient of friction. While the coefficient of friction changes as the vehicle decelerates from the initial speed to zero, the f in this formula is a single equivalent value that represents the entire speed change. Table 1.1 below provides the f used in the stopping sight distance calculation for various design speeds (1). The initial speed is preferably the design speed, although the minimum stopping sight distance may be based on the anticipated running speed for a particular design speed. The f has been found to be influenced by the condition of the road surface (wet, dry, ice, etc.), type of pavement surface, air pressure in tires, tire wear, and tire tread patterns. The f 's in the table below are for wet conditions that govern stopping sight distance and should cover such

things as all significant pavement surfaces, likely field conditions, worn and new tires, and most tread and tire compositions (1).

Table 1.1. Stopping sight distance (wet pavements)

Design Speed (km/h)	Assumed Speed for Condition (km/h)	Brake Reaction		Coefficient of Friction* f	Braking Distance on Level (m)	Stopping Sight Distance for Design (m)
		Time (s)	Distance (m)			
30	30-30	2.5	20.8-20.8	0.40	8.8-8.8	29.6-29.6
40	40-40	2.5	27.8-27.8	0.38	16.6-16.6	44.4-44.4
50	47-50	2.5	32.6-34.7	0.35	24.8-28.1	57.4-62.8
60	55-60	2.5	38.2-41.7	0.33	36.1-42.9	74.3-84.6
70	63-70	2.5	43.7-48.6	0.31	50.4-62.2	94.1-110.8
80	70-80	2.5	48.6-55.5	0.30	64.2-83.9	112.8-139.4
90	77-90	2.5	53.5-62.5	0.30	77.7-106.2	131.2-168.7
100	85-100	2.5	59.0-69.4	0.29	98.0-135.6	157.0-205.0
110	91-110	2.5	63.2-76.4	0.28	116.3-170.0	179.5-246.4
120	98-120	2.5	68.0-83.3	0.28	134.9-202.3	202.9-285.6

* Values of coefficient of friction generally approximate curves 9 and 10 (coefficient of friction for wet-PC concrete and wet-plant mixes) shown in Figure III-1A.

Source: Table III-1, 1994 AASHTO, Ref. 1, p. 120.

Along with f , Table 1.1 lists calculated reaction and braking distance (d_p and d_b) and stopping sight distance for various design speeds, where stopping sight distance is $d_p + d_b$. The upper-calculated stopping sight distance values are based on design speed, while the lower values are based on average running speed. For stopping sight distance calculations, the height of the object is considered to be 150 mm above the ground and the height of the driver's eye is assumed to be 1,070 mm above the ground (1 and 5). The assumed driver's eye height has decreased from earlier editions of AASHTO (1).

Concerns about the current stopping sight distance criteria have been expressed in various studies (24). One issue is that the brake reaction time of 2.5 seconds is based on 90 percent of the driver population in a 1971 study. Today, a larger portion of the driving population consists of elderly drivers, with that portion anticipated to increase. Therefore, it has been suggested that a brake reaction time of 3.5 seconds be used to better account for elderly drivers. Concern has also been raised as to the friction factors used in stopping sight distance calculations. These factors are based on studies of passenger vehicles undertaken between 1948 and 1962. Truck tire braking capability is typically 0.7 that of passenger car tires; this may need to be better reflected in design standards. Additionally, the side friction values were determined on the assumption that the vehicle is on a tangent section of roadway.

An alignment that is curved imposes a greater demand on the tires and increases the required braking distance (24).

Horizontal Curves

A horizontal curve is one of the two primary types of curves (horizontal and vertical). The horizontal curve standards represent the maximum degree of curve, or minimum radius. Most civil engineers are familiar with the basic formula for horizontal curvature.

$$e + f = \frac{V^2}{127R} \quad (1.3)$$

where

- e = rate of superelevation (decimal percent),
- f = side friction factor,
- V = vehicle speed (km/h), and
- R = radius of curve (m).

Figure 1.1 shows the basic relationships for a circular horizontal curve, while Figure 1.2 shows one derivation of Equation 1.3.

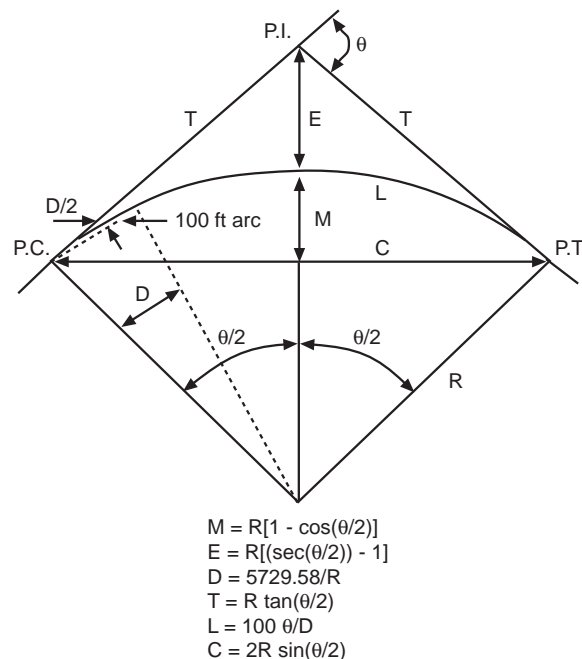
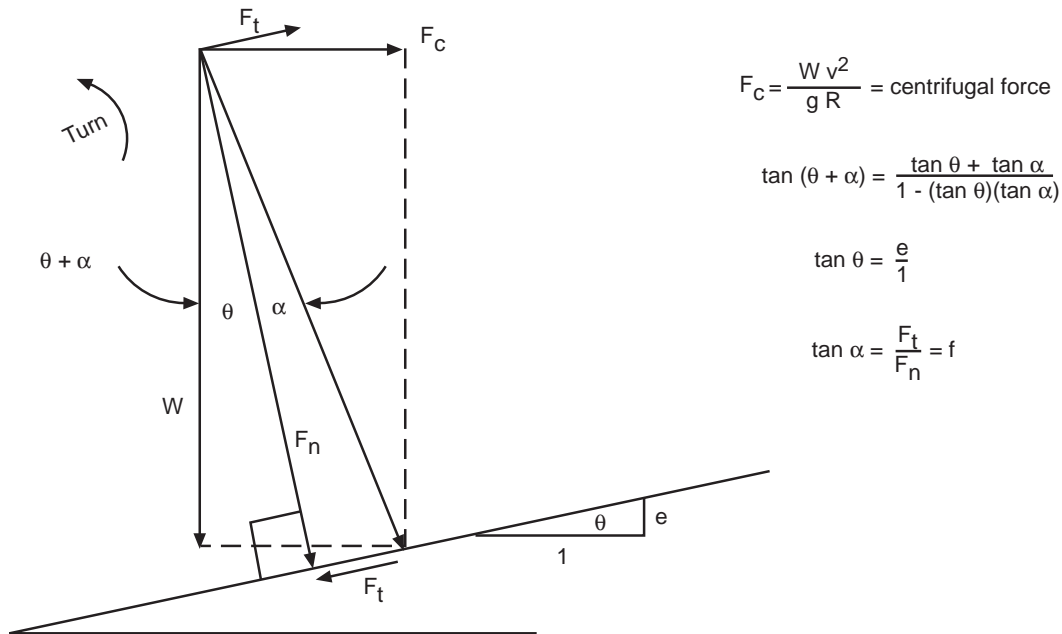

Figure 1.1. Horizontal curve basic elements



So

$$\tan (\theta + \alpha) = \frac{\frac{W v^2}{g R}}{W} = \frac{v^2}{g R} = \tan (\theta + \alpha) = \frac{\tan \theta + \tan \alpha}{1 - (\tan \theta)(\tan \alpha)} = \frac{e + f}{1 - ef}$$

$$\frac{e + f}{1 - ef} = \frac{v^2}{g R}$$

$$e + f = \frac{v^2}{127 R}$$

(Design approximation)

where

W = weight of vehicle

e = superelevation rate, decimal percent

g = acceleration due to the force of gravity, m/s/s

R = radius of circular curve, m

v = speed of vehicle, Km/h

f = side friction factor = $\frac{\text{Force tangential to pavement surface, } F_t}{\text{Force normal to pavement surface, } F_n}$

Figure 1.2. Derivation of horizontal (circular) curve

An instance of Equation 1.3, as given by AASHTO (1), is roughly as follows: A vehicle traveling on a nonsuperelevated curve develops the f necessary to resist centrifugal force, provided this f is less than the maximum attainable. A vehicle traveling at constant speed on a curve with an e such that f is zero theoretically requires no steering force, because the centrifugal force is balanced by the weight of the vehicle. When a vehicle is traveling at a

speed other than the balance speed, f is developed as steering effort is applied to prevent the vehicle from moving to the inside or outside of the curve.

AASHTO has established limiting values of e and f for different design speeds. The maximum superelevation is constrained by practical limitations. These limits can be affected by climate conditions (if an area is subject to ice and snow), increased potential for hydroplaning, area type (urban/rural), terrain conditions, driver discomfort at low speeds, and trucks with higher centers of gravity. Based on studies and experience, the maximum rate of superelevation on highways is typically 0.10, and occasionally 0.12. In areas subject to ice and snow, 0.08 provides a practical limiting value (1).

In addition to developing limiting values of superelevation, AASHTO has also studied design values for the side friction factor (f). Different pavement conditions, pavement types, and weather conditions have been studied, though it has been concluded that the maximum available side friction factor should not be used in design. Instead, one guide AASHTO uses is the following: "...the speed on a curve at which discomfort due to the centrifugal force is evident to the driver can be accepted as the design control for the maximum allowable amount of side friction." Side friction factors for design purposes range from 0.17 for 30 km/h to 0.09 for 120 km/h. Table 1.2, part of Table III.6 from AASHTO, provides the minimum radius for various design speeds and superelevation combinations.

Figure 1.3 from TxDOT's *Operations and Procedures Manual* illustrates the usual and absolute maximum degree of curve (minimum radius) for design speeds of 48, 64, 81, 97, and 112 km/h and a superelevation of 0.08. The absolute maximums are based directly on those calculated in AASHTO. This TxDOT figure refers the designer to the AASHTO design guide for maximum degree of curve (minimum radius) values that apply to superelevation rates other than 0.08. Figure 1.3 also lists the maximum degree of curve for highway curves without superelevation. Figure 1.4 from TxDOT's *Operations and Procedures Manual* shows the superelevation to be used for various design speeds and degrees of curvature where the limiting values from Figure 1.3 are not utilized. This table is also based on a maximum superelevation of 0.08.

An additional aspect of the effect of superelevation on design is the superelevation transition. This is the length of roadway over which the existing profile is changed to the desired superelevation and vice versa. For a simple circular curve, two-thirds of the transition should be made outside the curve and the remaining one-third within the limits of the curve. On spiral curves the transition is distributed over the spiral. On high-speed facilities, desirable design values for length of superelevation are based on using a maximum relative gradient of 0.5 percent between profiles of the edge of pavement and axis of rotation. This length is directly proportional to the change in pavement edge elevation owing to superelevation. The superelevation transition length is subject to minimum values of 38, 46, 53, and 61 meters for design speeds of 64, 81, 97, and 113 km/h, respectively.

Table 1.2. Minimum radius for design of all rural highways and high-speed urban streets using limiting values of e and f

Design Speed (km/h)	Maximum e (%)	Limiting Values of f	Total $(e/100+f)$	Calculated Radius (meters)	Rounded Radius (meters)
30	6.00	0.17	0.23	30.8	30
40	6.00	0.17	0.23	54.8	55
50	6.00	0.16	0.22	89.5	90
60	6.00	0.15	0.21	135.0	135
70	6.00	0.14	0.20	192.9	195
80	6.00	0.14	0.20	252.0	250
90	6.00	0.13	0.19	335.7	335
100	6.00	0.12	0.18	437.4	435
110	6.00	0.11	0.17	560.4	560
120	6.00	0.09	0.15	755.9	755
30	8.00	0.17	0.25	28.3	30
40	8.00	0.17	0.25	50.4	50
50	8.00	0.16	0.24	82.0	80
60	8.00	0.15	0.23	123.2	125
70	8.00	0.14	0.22	175.4	175
80	8.00	0.14	0.22	229.1	230
90	8.00	0.13	0.21	303.7	305
100	8.00	0.12	0.20	393.7	395
110	8.00	0.11	0.19	501.5	500
120	8.00	0.09	0.17	667.0	665
30	10.00	0.17	0.27	26.2	25
40	10.00	0.17	0.27	46.7	45
50	10.00	0.16	0.26	75.7	75
60	10.00	0.15	0.25	113.4	115
70	10.00	0.14	0.24	160.8	160
80	10.00	0.14	0.24	210.0	210
90	10.00	0.13	0.23	277.3	275
100	10.00	0.12	0.22	357.9	360
110	10.00	0.11	0.21	453.7	455
120	10.00	0.09	0.19	596.8	595

NOTE: In recognition of safety considerations, use of $e_{max} = 4.00\%$ should be limited to urban conditions.

Source: Table III.6, 1994 AASHTO, Ref. 1, p. 156

Previously, discussion was presented on safe stopping sight distance (SSD). Because that discussion presented the safe SSD for a straight roadway section, it is now necessary to extend safe SSD to horizontal curves. A review of Figure 1.1 is helpful in understanding this concept. If this figure is considered part of a horizontal curve, then M would represent the distance from the roadway inside lane to the sight line obstruction. The chord length then represents the line of sight with the arc length equal to the distance traveled. The requirement for safe stopping sight distance then simply becomes the required arc length (travel distance) necessary to react and stop once an object has been sighted along the line of sight. On a horizontal curve, the line of sight to an object is assumed to intercept the view obstruction at

the midpoint of the sight line. Figure 1.5 from the TxDOT design manual provides stopping sight distance for horizontal curves.

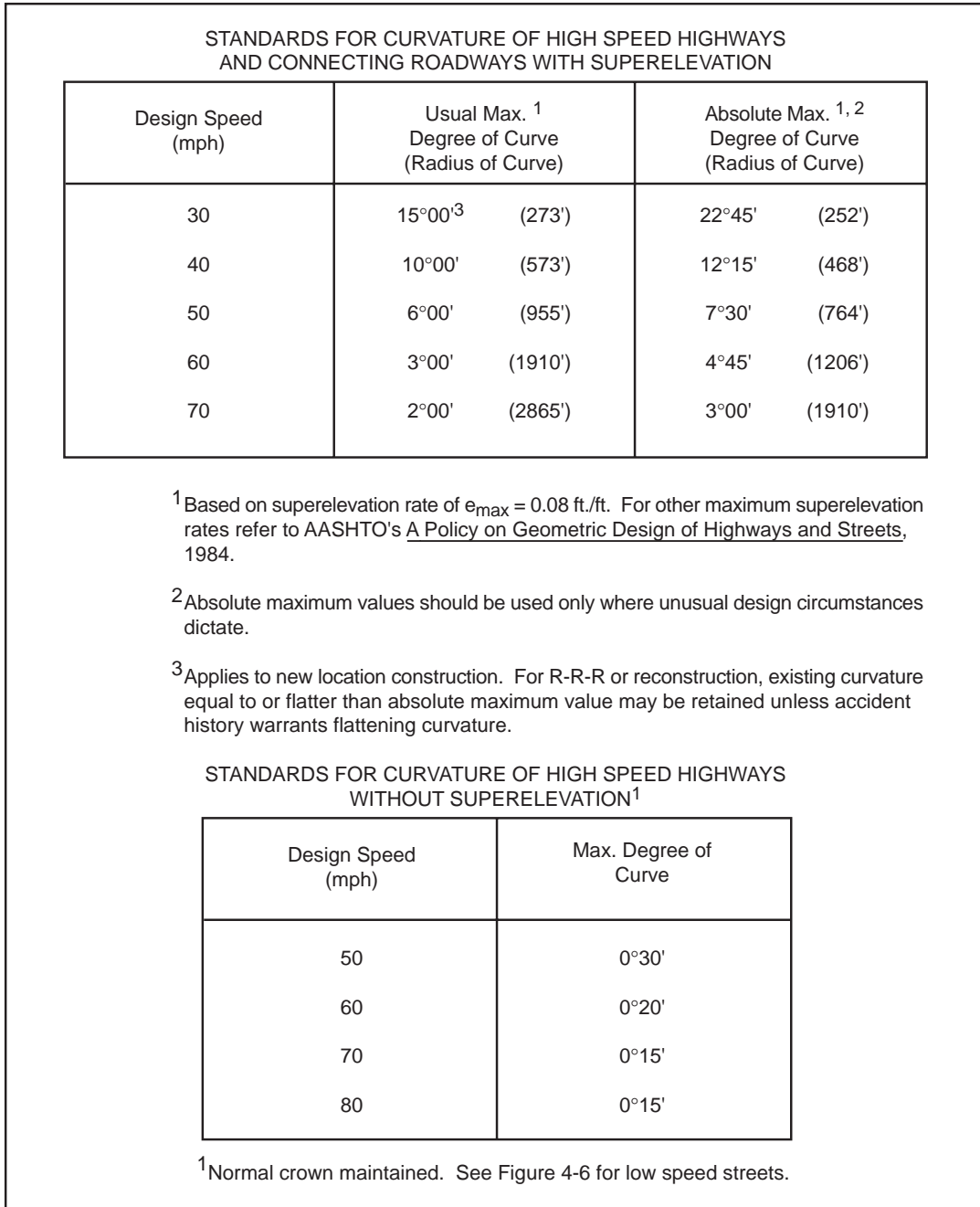

*Figure 4-4. Refers to Paragraph 4-202(D)1
(Source: Figure 4-4, SDHPT Operations and Procedures Manual, Ref. 5 p. 4-13)*

Figure 1.3. Texas curvature standards

VALUES FOR SUPERELEVATION RATE RELATED
TO CURVATURE ON HIGH SPEED HIGHWAYS

D	Radius	Superelevation Rate, e, for Design Speed of:			
		40 mph	50 mph	60 mph	70 mph
0°15'	22918'	NC	NC	NC	NC
0°30'	11459'	NC	NC	RC	RC
0°45'	7639'	NC	RC	.022	.028
1°00'	5730'	RC	.021	.029	.036
1°30'	3820'	.021	.030	.041	.051
2°00'	2865'	.027	.038	.051	.065
2°30'	2292'	.033	.046	.061	.075
3°00'	1910'	.038	.053	.068	.080
3°30'	1637'	.043	.058	.074	
4°00'	1432'	.047	.063	.078	
5°00'	1146'	.055	.071	.080	
6°00'	955'	.062	.077		
7°00'	819'	.067	.080		
8°00'	716'	.071			
9°00'	637'	.075			
10°00'	573'	.078			

NC = Normal Crown
RC = Reverse Crown

$e_{\max} = 0.08 \text{ ft./ft.}$

*Figure 4-10. Refers to Paragraph 4-202(D)4
(Source: Figure 4-10, SDHPT Operations and Procedures Manual, Ref. 5, p. 4-20)*

Figure 1.4. Texas superelevation standards

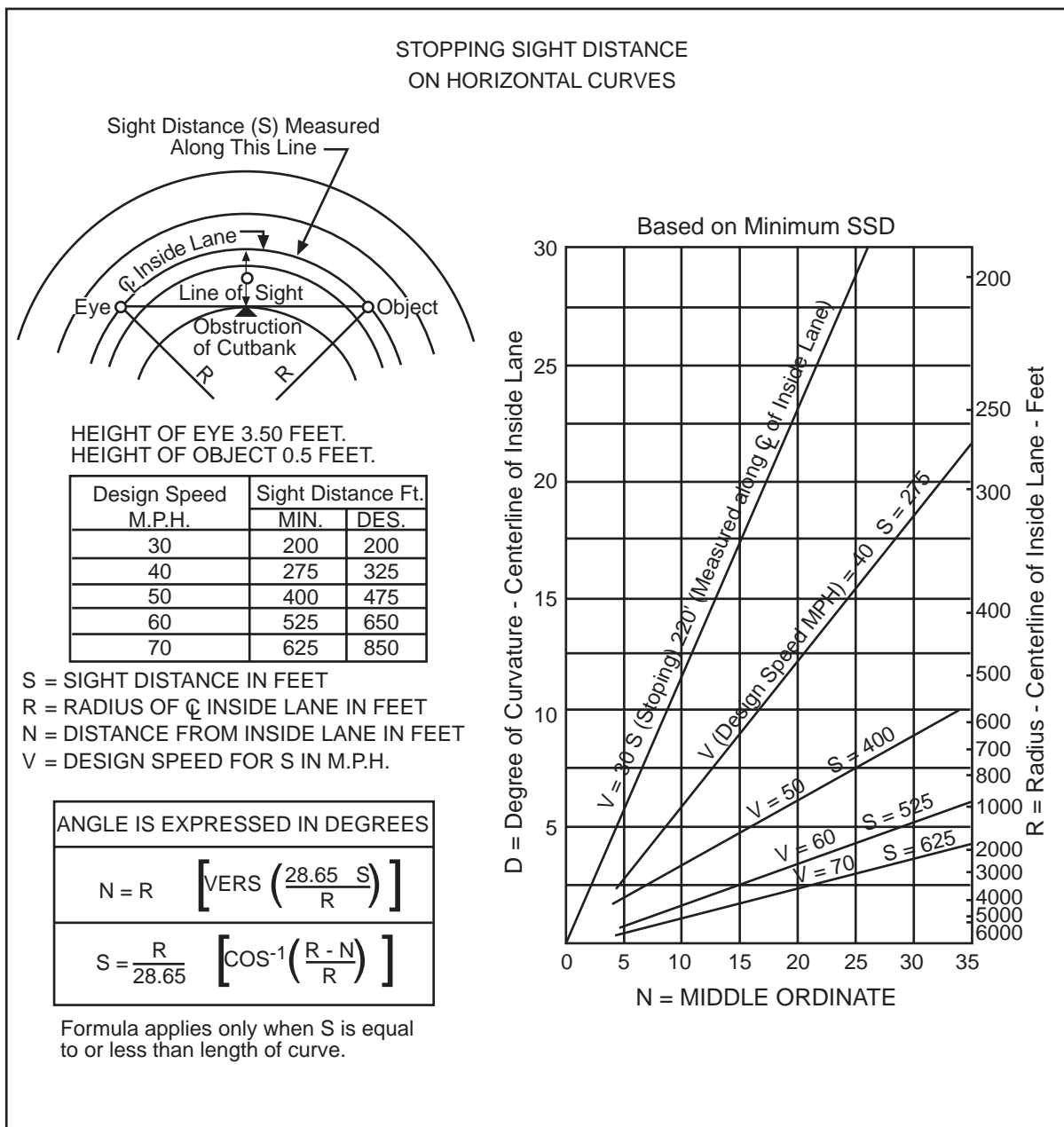

Figure 4-12. Refers to Paragraph 4-202(D)5
(Source: Figure 4-12, SDHPT Operations and Procedures Manual, Ref. 5 p. 4-23)

Figure 1.5. Texas stopping sight distance standards

Vertical Curves

The final basic geometric element to be discussed is vertical curves. The vertical curve is used wherever a change in elevation must be achieved. For example, a vertical curve

may be used to connect two portions of a roadway at different elevations. This often occurs on ramps where the connection of the ramp on one road is at an elevation different from that of the ramp connection to the other road. Also, a vertical curve is often used to connect two portions of the same roadway at the same elevation with a change in elevation between the two points, such as in the case of an overpass. A commonly used type of vertical curve is a parabolic vertical curve. Some properties of this curve are:

1. Tangents drawn from any two points on a vertical-axis parabola always intersect midway between the points of tangency where distance is measured horizontally. This is often referred to as an *equal-tangent vertical curve*.
2. Vertical offsets from a tangent to a parabola are proportional to the square of the distance from the point of tangency:

$$y = (k)x^2 \quad (1.4)$$

where

$$k = Y/L^2 \text{ or } Y/L^2 :: y/x^2$$

3. The external distance, E , and the middle ordinate, M , are equal, and

$$E = M = AL/800 \quad (1.5)$$

where

A = algebraic difference in grades, and

L = horizontal length of parabola.

4. The slope (gradient) of a tangent to the parabola changes a constant amount for each increment of horizontal distance.

$$K = L/A \quad (1.6)$$

where

K = horizontal distance to affect a 1 percent change in grade.

5. The highest or lowest point on the parabolic vertical curve lies between the vertical point of curvature (PVC) and the vertical point of tangency (PVT) where the slope of a tangent to the curve is zero.

Most vertical curves will be of the symmetric type, although in instances where this type of curve will not satisfy critical clearances or other controls, unsymmetrical curves may be used.

The predominant factor affecting the safe design of a vertical curve is the requirement for adequate sight distance at design speed, which at minimum should be safe stopping sight distance. Comfort is also a consideration and is typically more critical on sag curves, because both gravity and vertical centrifugal forces are acting in the same direction. Crest vertical curves typically have a minimum length controlled by sight distance requirements, with comfort and appearance generally satisfied. Equations 1.7 and 1.8 may be used in the determination of minimum L of a vertical parabolic curve. AASHTO and TxDOT provide figures based on these equations. Figure 1.6 (AASHTO Figure III.41, same as TxDOT Figure 4.17) is included as an example. Figure 1.6 provides the required lengths of a vertical curve for values of A from 0 to 16. This figure is based on the upper range of stopping sight distances from Table 1.1. Notice that there are some adjustments to the lower range of A and L values in the $S < L$ region. These adjustments are based on common design practices that suggest a minimum length for vertical curves. One guide AASHTO gives to reflect current practice is a minimum length of 3 times the design speed, or $L_{min} = 3V$. While not included in this report, AASHTO also provides a figure similar to Figure 1.6 based on the lower range of stopping sight distance values. Other considerations in the design of crest vertical curves that are further discussed in AASHTO are drainage and passing sight distance. These items are not discussed here, because, first, drainage need not necessitate a design limitation, only a factor that must be accounted for, and, second, passing is typically not an issue on ramps.

The process to determine the minimum length for a sag vertical curve tends to be more involved, with AASHTO highlighting four different criteria that must be met. These criteria include 1) headlight sight distance, 2) rider comfort, 3) drainage control, and 4) a rule of thumb for general appearance. Of these criteria, headlight sight distance is typically the governing factor. This criterion is based on the sight distance of a vehicle traversing a vertical curve being dependent upon the headlights' position, direction of the light beam, and curvature of the roadway. Equations 1.9 and 1.10 may be used in the calculation of the minimum sag length. The design objective for safety is that, on a sag vertical curve, the curve length be of adequate length such that the light beam distance is nearly the same as the stopping sight distance. As with the crest vertical curves, AASHTO has developed figures for the design controls for sag vertical curves for both the higher and lower ranges of stopping sight distance.

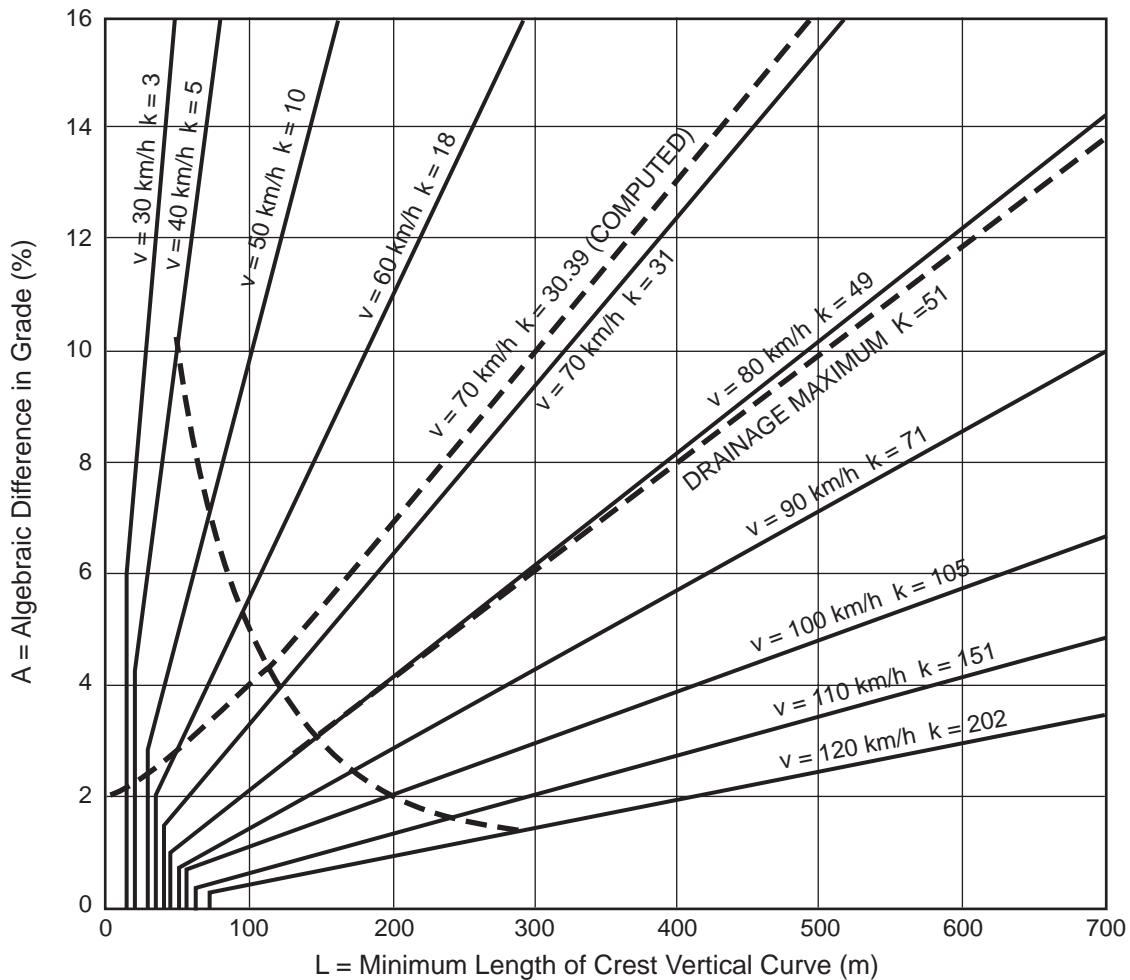

Figure 1.6. Design controls for crest vertical curves for stopping sight distance and open road conditions — upper range

As mentioned previously, comfort is a greater issue with sag vertical curves because of the compounding of gravitational and centrifugal forces. Comfort on a vertical curve is not simply a function of the curve itself, but also of the vehicle body suspension, tire flexibility, and vehicle weight. Based on limited studies, AASHTO states the general conclusion that centrifugal acceleration should not exceed 1 ft/sec^2 , which leads to Equation 1.13. Typically, this length is half that required for headlight distance; thus, comfort is not usually a governing factor.

In addition, as with the crest vertical curve, a minimum length of sag vertical curves is utilized in practice. The crest condition of $V = 3L$ is also used for sag vertical curves. Appearance and drainage are not discussed within this report, given that these conditions

rarely govern ramp design. A more complete discussion of these issues may be found in the TxDOT or AASHTO design guides. Other important aspects of vertical curves, which are discussed within the ramp design section of the report, are the effects of grades on operating performance and maximum allowable grades.

Formulas for vertical curve design:

Sight distance at crest:

$$\text{When } S < L, L = \frac{AS^2}{100(\sqrt{h_e} + \sqrt{h_o})^2} \quad (1.7)$$

$$\text{When } S > L, L = 2S - \frac{200(\sqrt{h_e} + \sqrt{h_o})^2}{A} \quad (1.8)$$

Headlight beam sight distance (sags):

$$\text{When } S < L, L = \frac{AS^2}{200(0.6 + Stan1^\circ)} \quad (1.9)$$

$$\text{When } S > L, L = 2S - \frac{200(0.6 + Stan1^\circ)}{A} \quad (1.10)$$

Underpasses:

$$\text{When } S < L, L = \frac{AS^2}{800\left(C - \frac{h_e + h_o}{2}\right)} \quad (1.11)$$

$$\text{When } S > L, L = 2S - \frac{800\left(C - \frac{h_e + h_o}{2}\right)}{A} \quad (1.12)$$

Minimum length for comfort:

$$L = \frac{AV^2}{395} \text{ AASHTO (Sags)} \quad (1.13)$$

Takeoff velocity:

$$V_{take-off} = \sqrt{\frac{1500L}{A}} \quad (1.14)$$

where

- L = Length of parabolic curve (m),
- A = algebraic difference in grades (%),
- C = vertical clearance at underpass (m),
- h_e = height of eye above road (mm), (Typ. 1070 mm),
- a = upward divergence of headlight beam (degrees),
- S = sight distance (m),
- y = height of headlight (m),
- V = speed (km/h), and
- h_o = height of object (mm), (typ. 150 mm).

INTERCHANGES AND RAMP TYPES

Before reviewing ramp design, the locations where ramps are used and the different types of ramps are presented. Finally, the current state of practice in ramp design is presented.

Interchanges

The ramps being studied for this report are typically utilized as part of an interchange or freeway-to-frontage road connection. Interchanges provide a separation of traffic movements and should be designed to provide the highest possible traffic service. With the numerous freeways, location constraints, varying capacity needs, and other individual location circumstances, different types of interchanges have been developed. TxDOT's Highway Design Division's *Operations and Procedures Manual* lists six basic types of interchanges. Figure 1.7 shows some of the various types of interchanges, which are described below.

Trumpet or Tee. This interchange type is commonly used for three-leg interchanges in the connection of a major facility with a freeway.

Diamond. The diamond is the most commonly utilized interchange type. It is particularly prevalent in urban settings where its low-area requirement is a major asset. Diamond interchanges are used predominantly for major-minor crossings.

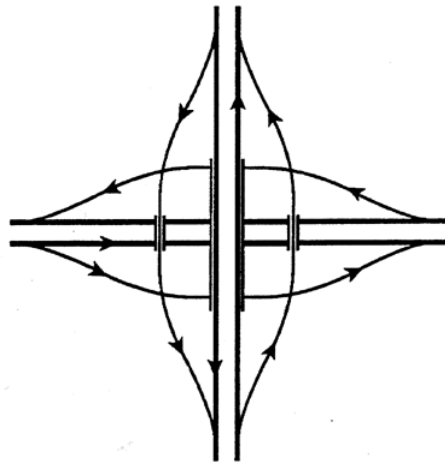

Three-Level Diamond

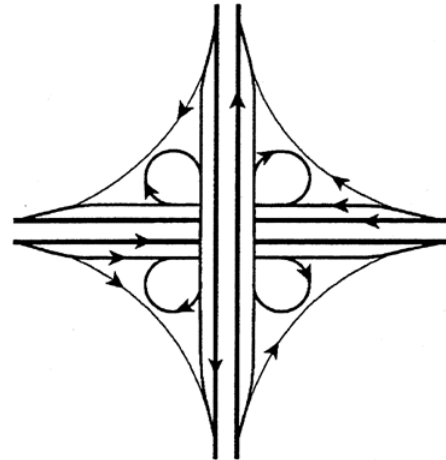

Cloverleaf

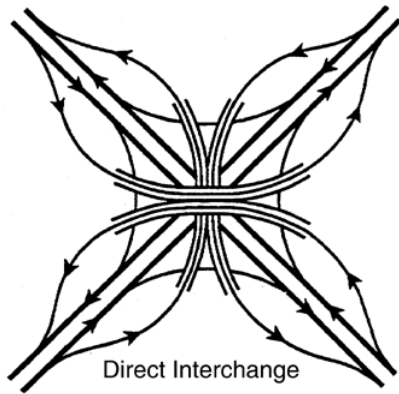

Direct Interchange

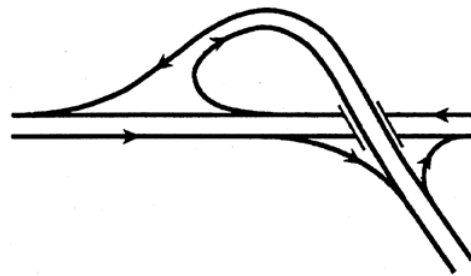

Trumpet

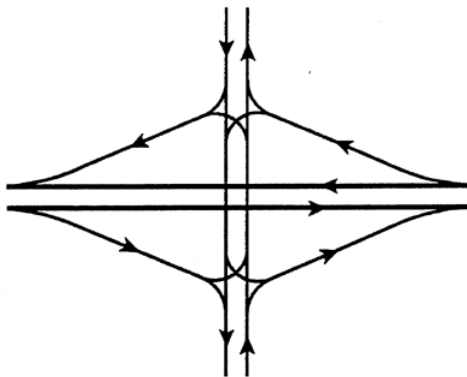

Conventional Diamond

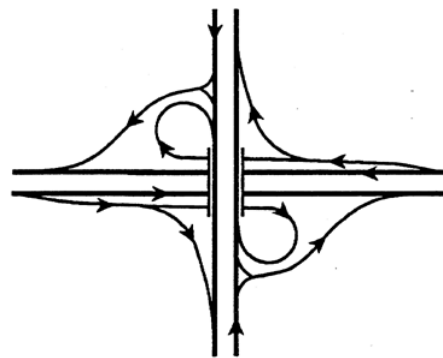

Partial Cloverleaf

Figure 1.7. Typical interchanges

Three-Level Diamond Interchange. These interchanges are typically used in urban areas where the cross street has high flows and where a regular diamond interchange will not provide adequate capacity. This facility is not recommended for the crossing of two controlled-access facilities.

Cloverleaf. The cloverleaf interchange is a two-level interchange that utilizes loop ramps in all four quadrants to eliminate left-turn conflicts. Cloverleaves are typically inappropriate at urban crossings of two controlled-access facilities owing to capacity restrictions of the loop ramps (i.e., traffic volumes should not exceed 1,200 vph on a loop ramp).

Partial Cloverleaves. Partial cloverleaves are similar to a cloverleaf interchange except that loop ramps are not utilized in all four quadrants.

Directional. An interchange that utilizes direct or semidirect connections for one or more left-turn movements is a directional interchange. An all-directional interchange has all turning movements on a direct or semidirect ramp. Directional interchanges provide speed and capacity improvements over cloverleaf and diamond interchanges.

As mentioned, ramps are also utilized in the connection of fully controlled-access facilities with frontage roads. Frontage roads and frontage road ramps may be incorporated into the above six interchange types. Frontage road ramps are often utilized in the connection of the freeway with the frontage road between interchanges.

A more in-depth discussion of the various interchange types and their possible configurations is beyond the scope of this study. For further information in this area, the reader is directed to the TxDOT and AASHTO design guides. An informative discussion on many of the issues to be considered when choosing an interchange configuration may be found in these resources, which identify not only the strengths and weaknesses of the different configurations, but also situations where a particular facility type may be appropriate or inappropriate. An understanding of these issues can facilitate planning and design decisions.

Ramp Types

For this report, a ramp is defined in accordance with the AASHTO design guide, which states that “the term ‘ramp’ includes all types, arrangements, and sizes of turning roadways that connect two or more legs at an interchange. The components of a ramp are a terminal at each leg and a connecting road, usually with some curvature, and on a grade.” The connecting roadway is often referred to as the *ramp proper*. This definition differs slightly from that provided in TxDOT’s *Operations and Procedures Manual*, which defines a ramp as what AASHTO refers to as the *ramp terminal* and the portion of roadway connecting to the ramp terminals as *connecting roadways*.

Figure 1.8 illustrates the different ramp types. (Not included in this illustration is a frontage road ramp.) The ramp types shown in Figure 1.8 are utilized in the configuration of the previously discussed interchanges. While there are numerous variations of these ramps in use, most ramps fit roughly into one of the ramp types illustrated. Specific variations of the shape of a ramp in each category may be influenced by such factors as traffic pattern, traffic volume, design speed, topography, culture, intersection angle, and type of ramp terminal. All the ramps discussed are typically one-way. The ramp types shown are described below.

Diagonal. Diagonal ramps are regularly used in connecting a minor nonfully controlled access facility to a fully controlled-access facility. The ramp in Figure 1.8 illustrates an on-ramp from the minor road to the freeway. However, diagonal ramps are also utilized as off-ramps from the freeway to the minor roadway. Commonly, both left- and right-turning movements exist at the ramp terminal with the minor road. Diamond interchanges typically utilize diagonal ramps. A type of diagonal ramp, usually called a *slip ramp*, is frequently used to connect a freeway to a frontage road.

One-Quadrant Ramp. As shown in Figure 1.8, this ramp is a type of loop ramp utilized in connecting two nonfully controlled-access facilities. In the illustration, there are double (left and right) turning movements at both ends of the ramp. It is also possible to have double turning movements at just one end of the loop with a single turning movement at the other end or single turning movements at both ends. The loop ramp often is more indirect than other ramp types.

Loop and Semidirect. This set of ramp configurations provides a portion of the typical “trumpet” layouts. The configuration shown is often referred to as a *jug handle*. The semidirect ramp provides what would be a left-turn movement at an at-grade intersection through a motion to the right followed by a reversal of direction to the desired direction. A semidirect ramp may also be used for right turns but usually is not because other ramps, such as diagonal ramps, may be utilized for this function. The semidirect ramp provides for travel distances that are less than that of a loop ramp but more than that of a directional ramp. The loop ramp associated with this semidirect ramp is seen to have single-turning movements at both ends and satisfies what would be a left-turn movement in an at-grade intersection.

Loop and Outer Connection. This is another example of a loop ramp having single turn movements at both ends. This configuration allows for a left-turning movement to be made without an at-grade crossing. Drivers instead travel straight through the intersection, then make a right onto the loop ramp and travel 270° to the desired freeway direction. Complementing the loop ramp is an outer connection. This ramp provides what would have been a right-turn movement at an at-grade intersection of the two roadways.

Directional. Of the ramps discussed, the directional ramp typically offers the highest speeds and capacity with the shortest travel distances. As shown in Figure 1.8, the directional ramp satisfies a left-turn movement through a direct connection of the two roadways.

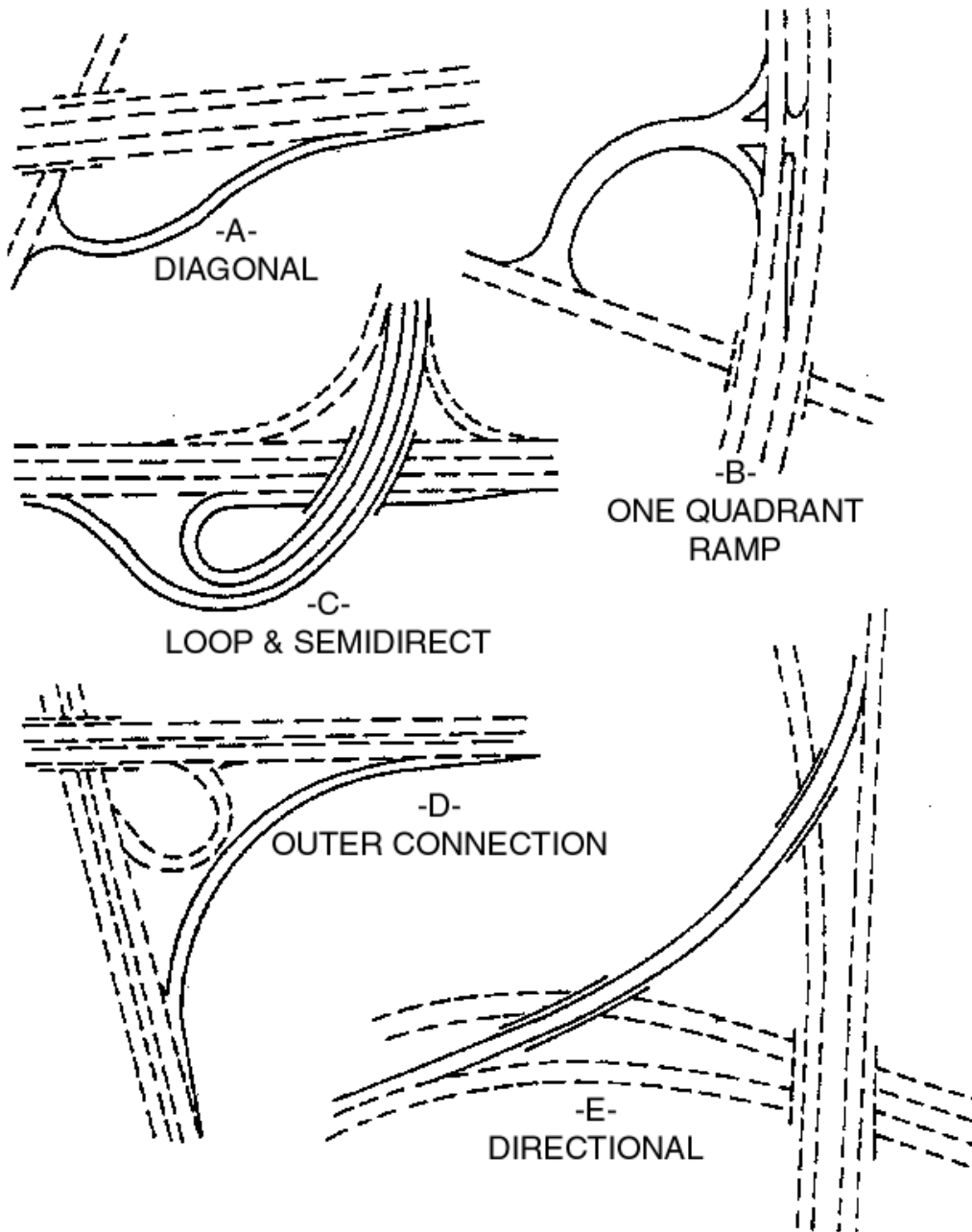

(Source: Figure X.62, 1994 AASHTO, Ref. 1, p. 917)

Figure 1.8. Ramp types

As mentioned, the above ramp types form the components of the discussed interchanges. For example, a full cloverleaf will consist of four loops and outer connections, while a trumpet may consist of two diagonal (or right directional) ramps — one semidirectional and one loop ramp.

RAMP DESIGN

The review of the basic elements of design and the different ramp types provides a foundation for reviewing current ramp design practices. The “current practices” as discussed in the report are based on TxDOT’s Highway Design Division’s *Operations and Procedures Manual* and on AASHTO’s *A Policy on Geometric Design of Highways and Streets* (1994). The effect of the choice of ramp design speed on the various geometric features and operational characteristics will be seen throughout this section.

Design Speed

The primary focus of this study is the current relationship between the design speed of the intersecting highway and the choice of ramp design speed. Current TxDOT practice prescribes that “all ramps and connections shall be designed to leave and enter the traveled way of the freeway at no less than 50 percent (70 percent usual, 85 percent desirable) of a freeway’s design speed.” Table 1.3, referenced from the AASHTO design guide, reflects the design guide values for ramp design speed and highway design speed. Figure 4.54 in the TxDOT design guide reproduces the design values for 80, 97, and 112 km/h.

According to AASHTO, ramp design speeds should approximate the low-volume running speeds on intersecting highways. Where this design speed is not practical, ramps should not be designed at less than 50 percent the design guidelines. For freeway and expressway ramps, only those values of highway design speed above 80 km/h apply.

Table 1.3. Guide values for ramp design speed as related to highway design speed

Highway Design Speed (km/h)	50	60	70	80	90	100	110	120
Ramp Design Speed (km/h)								
Upper Range (85%)	40	50	60	70	80	90	100	110
Middle Range (70%)	30	40	50	60	60	70	80	90
Lower Range (50%)	20	30	40	40	50	50	60	70
Corresponding Minimum Radius (m)	See Table III.16							

Source: 1994, AASHTO, Table X.1, Ref. 1, p. 918

These design values are considered to apply to the sharpest or the controlling ramp curve. This curve will usually be on the ramp proper; that is, on the roadway connecting the two ramp terminals. These design speeds are not considered to apply to the ramp terminals,

because the ramp terminals should be provided with speed-change facilities adequate for the highway speed involved. A discussion of ramp terminal design is provided in subsequent sections.

Earlier, several different types of ramps were discussed. AASHTO provides recommended guidelines for determining the design speed of the following ramp types.

Diagonal Ramps. Where a diagonal ramp is used for the right turns of a diamond interchange, a value in the middle range is practical.

Loops. Because it is not normally feasible to design a loop at the upper-range values, minimum values usually control each design. A review of the horizontal curvature and sight distance sections earlier in this report show the direct impact of design speed on curve radius. Design speeds above 48 km/h require large areas and long loops that are rarely practical in an urban setting. Large loops tend to be costly and require that left-turning drivers travel greater distances. The loop design speed should not be less than 40 km/h for highway design speeds over 80 km/h. Where conditions are less restrictive, the loop design speed may be increased.

Semidirect connections. Design speeds between the middle and upper ranges should be used with a minimum acceptable design speed of 48 km/h. Additionally, it is typically not practical to utilize a design speed greater than 80 km/h for short, single-lane ramps.

Direct connections. As with the semidirect ramp, the design speed for direct ramps should be between the middle and upper ranges, with a desirable minimum design speed of 64 km/h. The minimum design speed should not be less than 56 km/h in any case.

In situations where a ramp connects two intersecting highways, the ramp design speed is based on the highway having the higher design speed. However, it may be acceptable to vary the design speed, with the portion of the ramp closer to the higher design speed highway based on the higher speed, and the portion of the ramp closer to the lower design speed highway based on the lower speed. Where the ramp is used to connect a freeway to a major crossroad or street forming an at-grade intersection where signal or sign control may be in effect, the design of that portion of the ramp at the crossroad is based on intersection design controls.

Superelevation and Side Friction Factor

Earlier discussion was presented on the factors and assumptions that affect the design of horizontal curves. This discussion now applies directly to ramp curves. While simple circular curves were the focus of that discussion, ramps may also utilize compound curves and spiral transitions to meet site conditions and other controls. While the methodology for ramp curves does not change from the horizontal curve discussion, there are some differences in the limiting values of the superelevation and side friction factors. According to the AASHTO design guide, ramps designed at 64 km/h should have the superelevation rates shown in Table 1.4. These rates are to be applied to the design of curves at intersections.

Both TxDOT and AASHTO utilize the above table, though TxDOT follows the table only for design speeds of 40 km/h and above. These rates have been developed based on

driver expectation at an intersection and, subsequently, on ramps of lower design speeds. AASHTO states that drivers anticipate the sharp curves and accept operation with side friction factors higher than those on open highway curves (1). In designing an intersection curve, the desire is to provide as much superelevation as possible, preferably in the upper half or third of the indicated range (1 and 5). When a radius greater than the minimum for a given design speed is used, the curve should be superelevated at less than the maximum rate to achieve design balance (1).

Table 1.4. Superelevation rates for curves at intersections

Radius (m)	Range in Superelevation Rate (decimal %) for Intersection Curves with Design Speed (km/h) of					
	20	30	40	50	60	70
15	.02-.10	—	—	—	—	—
25	.02-.07	.02-.10	—	—	—	—
50	.02-.05	.02-.08	.04-.10	—	—	—
70	.02-.04	.02-.06	.03-.08	.06-.10	—	—
100	.02-.03	.02-.04	.03-.06	.05-.09	.08-.10	—
150	.02-.03	.02-.03	.03-.05	.04-.07	.06-.09	.09-.10
200	0.02	.02-.03	.03-.04	.03-.05	.05-.07	.07-.09
300	0.02	.02-.03	.02-.03	.03-.04	.04-.05	.05-.06
500	0.02	0.02	0.02	.02-.03	.03-.04	.04-.05
700	0.02	0.02	0.02	0.02	.02-.03	.03-.04
1000	0.02	0.02	0.02	0.02	0.02	.02-.03

NOTE: It is preferable to use superelevation rate in upper half or third of indicated range. In areas where snow or ice is frequent, use maximum rate of 0.08.

Source: 1994, AASHTO, Table IX-12, Ref 1, p. 730

As stated, Table 1.4 is based on an acceptance of higher side friction factors at intersection curves and, subsequently, on lower speed ramps. The higher side friction factors are based on several studies referenced by AASHTO that were conducted to determine lateral vehicle placement and distribution of speeds on intersection curves. These studies utilized the 95th-percentile speed of traffic to represent the design speed, assuming that the design speed is usually adopted by the faster drivers. Using the side friction factors for high speeds (as developed for Table 1.2) as an upper limit and a maximum low speed side friction factor of 0.5, it became possible to develop a relationship between the 95th-percentile speed (assumed design speed) and the side friction factor for the observed vehicles.

Now, utilizing these side friction factors and assumptions for superelevation rates that may be developed on an intersection, minimum radii for various design speeds were

developed. The superelevation utilized in the determination of the minimum radius accounts for intersection curves typically being of shorter lengths and, therefore, not having sufficient distance to develop large superelevations. AASHTO Table III.17 (Table 1.5 of this report) presents the calculation of minimum radii for the design speeds from 16 to 64 km/h based on the discussed side friction factors and superelevation assumptions.

Table 1.5. Minimum lengths of spiral for intersection curves

Design (turning) speed (km/h)	30	40	50	60	70
Minimum radius (m)	25	50	80	125	160
Assumed C	1.20	1.10	1.00	0.90	0.80
Calculated length of spiral (m)	19	25	33	41	57
Suggested minimum length of spiral (m)	20	25	35	45	60
Corresponding circular curve offset from tangent (m)	0.70	0.70	0.70	0.80	0.90

Source: 1994, AASHTO Table III-17, Ref. 1, p. 198

A comparison of the intersection side friction factor with the open highway side friction factor from Table 1.2 demonstrates large differences at the lower design speeds with decreasing differences as the design speed approaches 64 km/h. For example, at a design speed of 32 km/h the difference in f is $0.27 - 0.17 = 0.10$, whereas at a design speed of 64 km/h the difference is just $0.16 - 0.15 = 0.01$.

The ramp design typically affected by the acceptance of higher side friction factors at lower design speeds is the loop ramp. Table 1.4 (AASHTO Table IX.12) indicates that a loop ramp with a design speed of 50 km/h will have a minimum radius of 70 m with an allowable superelevation from 0.06 to 0.10. The open road version with the same design speed would have a radius of 90 m and a 0.06 superelevation, or 75 m for a superelevation of 0.10 (see Table 1.2). Because direct and semidirect ramps are generally designed for higher speeds and are longer, superelevation rates and side friction factors comparable to those in Table 1.2 (AASHTO Table III.6, "open road conditions") are commonly used. For a diamond ramp, the exit is usually high speed with a tangent or curved ramp proper and stop or yield conditions at the ramp forward terminal. The vehicle's deceleration to the curve design speed should occur on the auxiliary lane of the exit with further deceleration to meet the stop or yield controls occurring on the ramp proper. Thus, superelevation for the ramp proper having a lower design speed, and certainly the forward terminal, will be based on Table 1.4, "intersection conditions," not on Table 1.2, "open road conditions."

Harwood and Mason (22) offer further discussion of the different superelevations that may be applicable in ramp design. They state that the AASHTO reason for the different methods used in determining minimum radii is that Table 1.3 (AASHTO Table X.1) also may be utilized in determining ramp design on arterials and collectors. For the lower design speed facilities it is more reasonable to use the higher side friction factors, as discussed earlier. So,

for arterials and collectors with design speeds under 80 km/h, Harwood and Mason recommend utilizing Table 1.3 in the same manner as for freeways, only utilizing AASHTO Table 1.5 instead of Table 1.2. Figure 1.9 is offered by Harwood and Mason to clarify the use of Table 1.3.

Functional Classification	Highway Design Speed (mph)									
	30	35	40	45	50	55	60	65	70	
Freeway or Expressway	NOT APPLICABLE				Use Table III - 6					
Arterial	Use Table III - 17			Minimum: Use Table III - 17						
Collector				Desirable: Use Table III - 6						

(Source: Figure 1, Ref. 22, p. 123)

Figure 1.9. Horizontal design criteria for ramps

It should be readily noticed that this figure contradicts much of the earlier discussion on the design of loop ramps. Harwood and Mason are stating that, on a freeway ramp, regardless of the ramp design speed, the open roadside friction factors and superelevation should be utilized. This figure appears to be in direct conflict with the discussion in AASHTO where loop ramps of low design speed are designed according to Table 1.4, which is directly dependent on Table 1.5, the low speed criteria. Harwood and Mason recognize this contradiction but state they believe it was not the intention of AASHTO to sanction the lower-curve radii on a freeway, believing instead the choice of design criteria is intended to be based on highway functional classification and highway design speed, not on the ramp design speed. This interpretation in choosing ramp design criteria appears to be supported in such other literature as the *Design of Interchange At-Grade Ramp Terminals* (25).

Additional concerns regarding the side friction factors and, subsequently, superelevation have been raised in other studies. J. Keller (24) discusses some of these concerns. A primary issue is the application to truck operation, where the limiting factor is “likely to be rollover rather than skidding.” The superelevation rates currently recommended by AASHTO are stated as having a very small margin of safety. Keller references one study (38) in which “the report states that more superelevation is required than is called for by AASHTO policy to produce the intended lateral acceleration at design speed for these drivers on an AASHTO criteria highway curve” (24).

The issues identified by Harwood, Mason, Keller, and others raises concerns with the AASHTO guide and, subsequently, the TxDOT guide. Two different interpretations of how the minimum ramp design should be implemented have been presented. It becomes important to clarify as part of any study what design parameters are intended by the minimal

50 percent design standard and if they provide acceptable design. Increased importance is now placed on determining not only the acceptableness of AASHTO minimum design standards for Texas, but also on clarifying the acceptable design parameters of any minimum ramp design speed.

Sight Distance

Sight distances along ramps should be at least as great as the safe stopping sight distance. The calculations involved in determining safe stopping sight distance on horizontal and vertical curves discussed previously apply directly to ramps. Sight distance is addressed in the TxDOT *Operations and Procedures Design Guide* as follows (5):

On all ramps and direct connections, the combinations of grade, vertical curves, alignments and clearance of lateral and corner obstructions to vision shall be such as to provide sight distance along such ramps and connections from terminal junctions along the freeway, consistent with the probable speeds of vehicle operation.

Within the ramp design section, the TxDOT guide provides a table for minimum stopping sight distance and desirable stopping sight distance for various design speeds. While this table is not included within this report, the stopping sight distances are identical to those found in AASHTO Table 1.1 shown earlier. Additional considerations from AASHTO include a recommendation that the freeway preceding an exit ramp should have a sight distance for through traffic based on the highway design speed that exceeds the minimum stopping sight distance by at least 25 percent (1).

Grades

AASHTO recommends that ramps be as flat as possible but states that “the flatter the gradient on a ramp, the longer it will be, but the effect of the gradient on the length of the ramp is less than generally thought. The conditions and designs at ramp terminals frequently have an effect equally as great.” A ramp will typically consist of a central portion with a high grade, while the ramp terminals will be of lesser grades. The limiting gradient of this central portion of the ramp is influenced by the effect of the steepness and length of the grade on vehicle operations and by the need to provide adequate sight distance (see the vertical curve discussion regarding sight distance). It is readily understood that the ramp design speed ramp will be predominant in both of these factors. The general AASHTO guidelines for ramp gradients follow an expectation that higher ramp design speeds will have flatter gradients. The AASHTO general criteria are as follows:

It is desirable that ascending gradients on ramps with a design speed of 70.80 km/h be limited to 3 to 5 percent; those for 60 km/h speed, to 4 to 6 percent;

those for a 40 to 50 km/h speed, to 5 to 7 percent; and those for a 30 to 40 km/h speed, to 6 to 8 percent. Where topographic conditions dictate, grades steeper than desirable may be used. One-way descending gradients no ramps should be held to the same general maximums, but in special cases they may be 2 percent greater. (1)

The ramp terminal grades are largely determined by the through-road profiles.

The TxDOT standards differ slightly from those described in the AASHTO discussion. TxDOT utilizes the same vertical curve relationships as AASHTO, except that it uses the minimum length for crest vertical curves, discussed in the vertical curve section, for determining the minimum length of ramp crest and sag vertical curves. This results in shorter minimum sag vertical curves at speeds below a 64 km/h design speed and longer minimum sag vertical curves at speeds above 64 km/h. The TxDOT guide also states that the “tangent or controlling grade on ramps should be as flat as possible, and preferably should be limited to 4 percent or less.” Because this standard does not account for differing design speeds, as does the AASHTO manual, it is a more conservative standard.

Other Ramp Design Issues

In general, ramps should be designed as single-lane facilities with provision for emergency parking; where the capacity of a one-lane ramp is not sufficient, a two-lane facility may be provided. Also, right-hand ramps are considered superior to left-hand ramps in operation and safety characteristics.

While not thoroughly discussed in this report (because it is not critical to acceptable minimum design), a ramp design will probably require superelevation runoff through a superelevation transition. If the minimum ramp length does not provide adequate length for this superelevation transition, then the ramp will require lengthening or the design speed and superelevation chosen will need to be revisited. Loop ramps provide an example where superelevation must typically be developed into and out of the ramp proper. Also not discussed in this report are ramp gore design and pavement widths. While related to highway and ramp design speeds and impacted by the type of ramp and ramp design, the effect of gore design and ramp pavement width is not critical to the ramp design questions under study. For an in-depth review of these topics the reader is directed to the TxDOT manual and to the AASHTO design guide.

Ramp Terminals

Much of the discussion of ramp design thus far has centered on the design of the ramp proper: minimum curve radius, superelevation, side friction, and grade. Discussed next is the design of the ramp terminal; that is, the portion of the ramp adjacent to the through travel way. There are two distinct operating scenarios for ramp terminals. A ramp terminal may be free flow with traffic merging or diverging at flat angles, such as ramps adjacent to a freeway, or the ramp may terminate to a minor road, such as a cloverleaf ramp into the crossroad at an

interchange. Free-flow ramps represent the area of interest for this report and, thus, for the design discussion that follows. Discussion of the other ramp type may be found in the TxDOT and AASHTO design guides.

General. Ramp terminal design must account for sight distance and the design of the ramp proper. The AASHTO manual presents a concise example of some important considerations:

Profiles of ramp terminals should be designed in association with horizontal curves to avoid sight restrictions that will adversely affect operations. At an exit into a ramp on a descending grade, a horizontal curve ahead should not appear suddenly to a driver using the ramp. Instead the initial crest vertical curve should be made longer and sight distance over it increased so that the beginning and the direction of the horizontal curve are obvious to the driver in sufficient time for safe operation. At an entrance terminal from a ramp on an ascending grade, the portion of the ramp and its terminal intended for acceleration should closely parallel the through-lane profile to permit entering drivers to have a clear view ahead, to the side, and to the rear on the through road. (1)

Desirably, ramp terminals are placed before the interchange and on the right-hand side of the freeway. Adequate sight distance must be provided on the freeway before the ramp terminal to allow for decision making and maneuvering. Also, consideration must be given to the ramp terminal placement vis-à-vis the distance between the free-flow terminal and the structure. If the terminal must be placed on the far side of the structure, then adequate distance should be allowed so exiting drivers, after passing the structure, have a distance sufficient for viewing the terminal and for maneuvering in whatever way necessary for safe exiting. Typically, the distance required between a ramp preceding the interchange structure and the structure is not as great as the distance required between the structure and a ramp terminal on the far side.

Speed-Change Lanes. The speed-change lane is a critical portion of any ramp terminal design. For this discussion the AASHTO definition of the speed-change lane is adopted where the speed-change lane refers to “the added pavement joining the travel way of the highway with that of the turning roadway and does not necessarily imply a definite lane of uniform width.” The speed-change lane is commonly referred to as the acceleration or deceleration lane. It is within the speed-change lanes that motorists exiting the freeway decelerate to the ramp proper design speed and entering motorists accelerate to a speed adequate for merging with through traffic. To accommodate this, the length of the speed-change lane should be long enough to enable a driver to change speed, in a safe and comfortable manner, from the highway speed to the ramp speed. As stated in the AASHTO design guide, a primary consideration for acceleration lane length is the need for a distance sufficient to permit speed adjustments of both the through and entering vehicles, so entering

vehicles may find and maneuver into a gap before the acceleration lane. A later section of this report will provide an in-depth review of freeway gap acceptance and merging.

When considering freeway ramp terminals and speed-change lanes, there are two basic designs: taper and parallel. The taper type involves direct entry or exit of the vehicle at a flat angle; the parallel type utilizes an added lane for speed changes. In theory, the taper type fits well with drivers' desired paths and reduces the amount of steering control necessary, especially on exit ramps. However, the taper type entrance ramp requires the driver to time-share between accelerating, gap search, and steering tasks (23). Figure 1.10 (from the AASHTO design guide) illustrates both design types for single-lane entrances, while Figure 1.11 illustrates both design types for exits.

Taper Type Entrances. When properly designed, the taper type entrance functions smoothly at all volumes, including the design capacity of the merging area. The AASHTO design guide recommends that the entrance ramp be brought into the freeway at a rate of 50:1 to 70:1, between the outer edge of the acceleration lane to the inside edge of the freeway. The desire of the AASHTO standards is to create a taper type design such that a vehicle may reach a speed approximately 8 km/h less than the average highway running speed by the point the left edge of the ramp meets the right edge of the travel way. For consistency, AASHTO sets this point to be where the right edge of the ramp and travel way are 3.7 m apart. The length required for a vehicle to achieve a speed 8 km/h below the average running speed is referred to by AASHTO as the acceleration length, L_a ; this is shown in Figure 1.10. This length is typically measured from the end of the governing curve on the ramp proper to where the right edges of the ramp proper and through lane are 3.7 m apart. This distance is based on the speed differential between the average running speed on the curve entrance and the highway. Table 1.6 (AASHTO Table X.4) gives the value of this distance for various curve design speeds and highway design speed combinations. (The source of these lengths will be discussed in a later section of this report.) In addition to the minimum acceleration length determined, the AASHTO design guide requires a check to determine that a minimum gap acceptance length is met (see Figure 1.10). Adjustments are also provided for the existence of grades, lengthening L_a on upgrades and decreasing L_a on downgrades.

Parallel Type Entrance. On the parallel type ramp, the vehicle is assumed to accelerate to the near-freeway speed necessary for merging on the parallel acceleration lane. At the end of the acceleration lane there is a taper to guide a vehicle onto the freeway through-lanes. AASHTO recommends a 93 m taper for highway design speeds up to 112 km/h. The difference between the two types of ramps (taper and parallel) is not the minimum acceleration length required, but, rather, the point where it is measured. For the parallel type, the entrance length of the acceleration lane is measured from the point where the left edge of the ramp meets the right edge of the freeway to the beginning of the taper; that is, acceleration on the parallel type ramp occurs in the lane parallel to the freeway through-lanes, downstream from the point of convergence of the freeway and ramp, whereas acceleration on the taper type ramp occurs on the ramp proper, upstream from the point of convergence of the

two roadways. An exception to this may occur where a parallel type ramp has a large radius upstream of the convergence point, and where the motorists view of the freeway while on the ramp is unobstructed. Under these conditions part of the ramp proper may be used as part of the acceleration length. Where the freeway and ramp are anticipated to carry volumes approximating the design capacity of the merging area, AASHTO recommends a minimum length of at least 373 m plus taper. Figure 1.10 illustrates a typical parallel type entrance ramp terminal and the minimum acceleration distance for parallel type speed change, as given by Table 1.6.

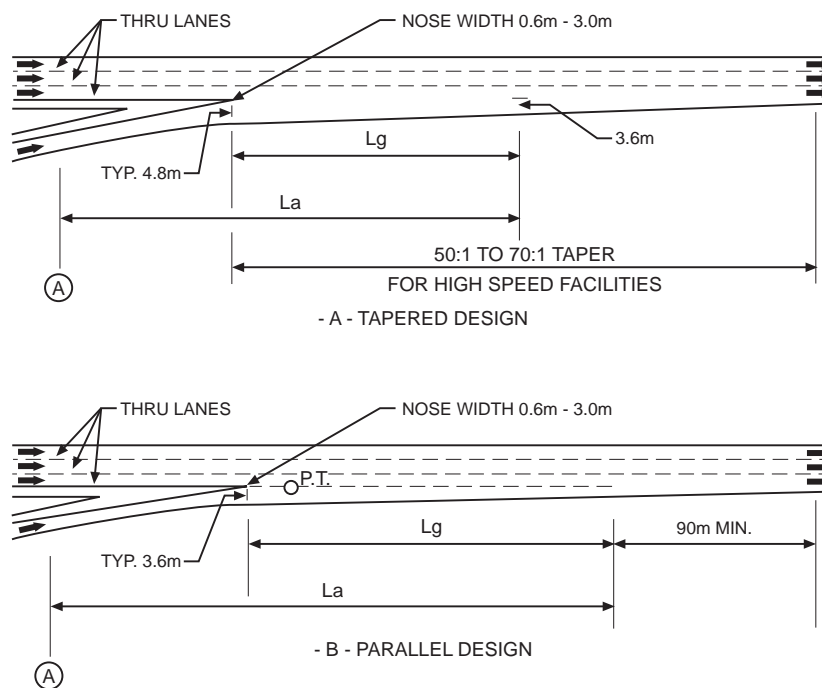

NOTES:

1. L_a IS THE REQUIRED ACCELERATION LENGTH AS SHOWN IN TABLE X-4 OR X-5.
2. POINT A CONTROLS SAFE SPEED ON THE RAMP. L_a SHOULD NOT START BACK ON THE CURVATURE OF THE RAMP UNLESS THE RADIUS EQUALS 300m OR MORE.
3. L_g IS REQUIRED GAP ACCEPTANCE LENGTH. L_g SHOULD BE A MINIMUM OF 90m TO 150m DEPENDING ON THE NOSE WIDTH.
4. THE VALUE OF L_a OR L_g , WHICHEVER PRODUCES THE GREATEST DISTANCE DOWNSTREAM FROM WHERE THE NOSE WIDTH EQUALS 0.6m IS SUGGESTED FOR USE IN THE DESIGN OF THE RAMP ENTRANCE.

(Source: Figure X.73, AASHTO, 1994, Ref. 1, p. 946)

Figure 1.10. Tapered and parallel entrance ramp designs

Taper Type Exit. The taper type exit generally provides a clear indication of the point of departure from the through-lanes and fits well into the path preferred by most drivers. The typical divergence angle of the taper type exit is between 2° and 5°. Figure 1.11 shows a typical tapered design. AASHTO states that deceleration typically begins after the vehicle leaves the through-lanes and should be completed before the vehicle reaches the point of limiting design speed on the ramp proper. Much like the taper entrance ramp, the deceleration distance may be considered to be the point where the ramp lane and thruway lane's right edges are 3.7 m apart to the point governing the safe speed on the ramp. This distance must be adequate to allow the vehicle to decelerate from the highway speed to the desired ramp speed, which may be a complete stop should the ramp terminate into a crossroad or a critical speed determined by the ramp curvature. The deceleration distance is calculated in much the same manner as the acceleration distance for entrance ramps. Table 1.7 (AASHTO Table X.6) gives deceleration distances for various highway design speed/ramp design speed combinations.

Parallel Type Exit. The parallel type exit terminal is similar to the parallel entrance ramp. Generally, the speed-change lane begins with a taper (78 m recommended) followed by a deceleration lane of length given in Table 1.7. The length of the deceleration lane is measured from the point where the right edges of the through lane and speed-change lane are 3.7 m apart to the point where the ramp and roadway separate. As with the entrance ramp, a portion of the ramp proper may be used as part of the deceleration length if that portion of the ramp has a large radius of curvature. Also, both parallel and taper type ramp deceleration lengths are adjusted for grades, with deceleration length increasing on downgrades and decreasing on upgrades.

Again, like the two entrance ramp types, it is assumed that on the parallel type ramp deceleration occurs before the right edge of the freeway and left edge of the ramp separate, whereas on the taper type the deceleration is assumed to occur after the two roadways separate. AASHTO recognizes that on the parallel type ramp terminal, motorists do not always utilize the deceleration lane; instead, they may decelerate in the through-lane and wait to maneuver onto the ramp when in the vicinity of the exit nose. This situation seems most prevalent under low-volume conditions.

This observation has been verified by research that has shown that even when a ramp is of the parallel type, nearly all exiting vehicles tend to drive directly for the ramp proper, not fully utilizing the parallel speed-change lane, but essentially utilizing the same path as when exiting on a taper type design (23, 27). In one study (27), the researchers found that between 85 percent to 95 percent of the vehicles observed began to enter the deceleration lane before the end of the taper section, although it was not until the end of the parallel section that 86 percent to 97 percent of the vehicles were entirely within the deceleration lane.

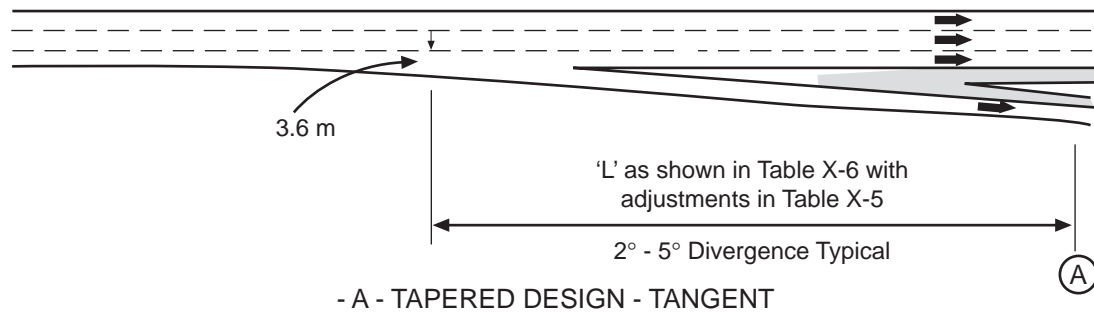

- A - TAPERED DESIGN - TANGENT

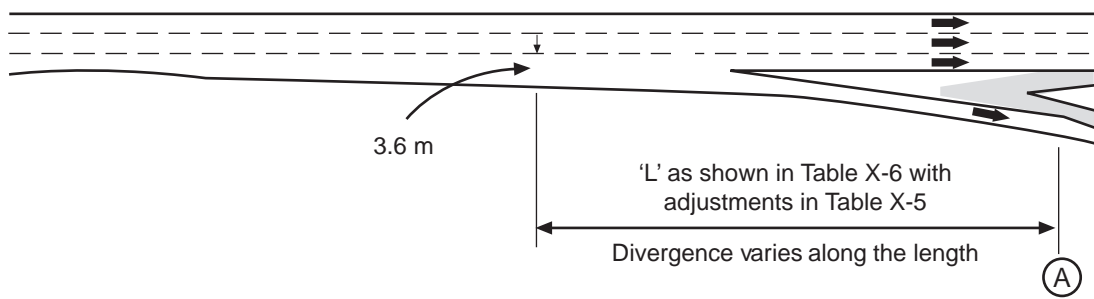

- B - TAPERED DESIGN - CURVILINEAR

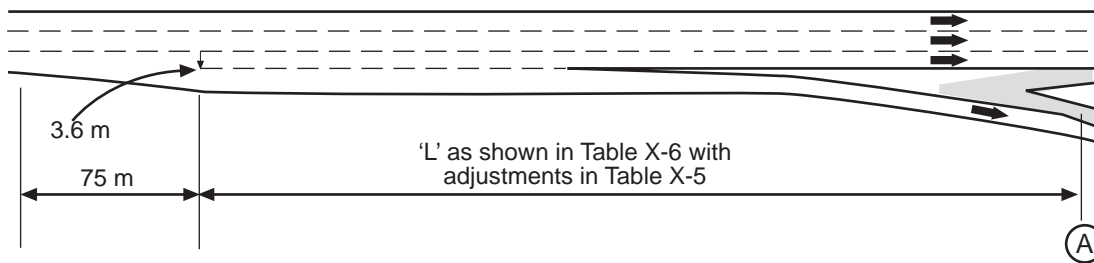

- C - PARALLEL DESIGN

(A) POINT CONTROLLING SAFE SPEED AT RAMP

(Source: Figure X-74, AASHTO, 1994, Ref. 1, p. 950-951)

(Source: Figure X.74, AASHTO, 1994, Ref. 1, p. 950.951)

Figure 1.11. Tapered and parallel exit ramp designs

Table 1.6. Minimum acceleration lengths for entrance terminals with flat grades of 2 percent or less

Highway Design Speed, V (km/h)	Speed Reached, V _a (km/h)	Acceleration Length, L (m)							
		For Entrance Curve Design Speed (km/h)							
		Stop Condition	20	30	40	50	60	70	80
			and Initial Speed, V' _a (km/h)						
		0	20	28	35	42	51	63	70
50	37	60	—	—	—	—	—	—	—
60	45	100	85	70	—	—	—	—	—
70	53	145	125	110	85	50	—	—	—
80	60	195	180	165	135	100	55	—	—
90	67	275	260	240	210	175	130	50	—
100	75	370	345	330	300	265	220	145	55
110	81	430	405	390	360	330	285	210	120
120	88	520	505	500	470	445	400	335	245

SOURCE: AASHTO, 1994, AASHTO, Table X-4, Ref. 1, Page 945

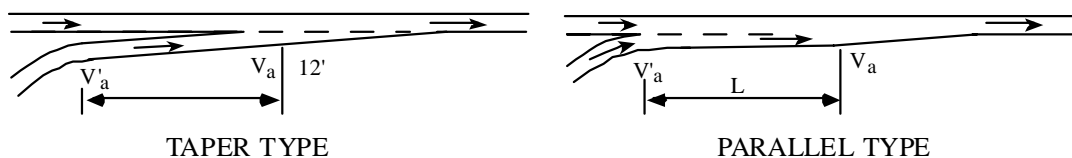

TxDOT Speed-Change Lane Design

The preceding discussion of speed-change lanes concentrated on the AASHTO approach to speed-change lane design. TxDOT has adopted standard designs that differ from this approach. Figures 1.12 through 1.17 show several of the TxDOT standard designs from the 1988 TxDOT design guide.

Entrance Ramps

A review of TxDOT's standard ramp designs reveals that TxDOT recommends one standard taper type entrance ramp design for all single-lane entrance ramps. This design consists of three sections: 1) a 75 m section upstream of the gore, 2) a 140 m section at a 50:1 taper downstream of the gore, and 3) a 187 m section tapered at 50:1, which serves to reduce the acceleration lane width from 3.7 m to 0 m. This design differs from the AASHTO design

in that only one standard speed-change lane length is utilized, whereas AASHTO utilizes varying speed change lane lengths according to Table 1.6.

Table 1.7. Minimum deceleration lengths for exit terminals with flat grades of 2 percent or less

Highway Design Speed, V (km/h)	Speed Reached, V _a (km/h)	Deceleration Length, L (m)							
		Stop Condition	For Design Speed of Exit Curve, V' (km/h)						
			20	30	40	50	60	70	80
		For Average Running Speed on Exit Curve, V'a (km/h)							
		0	20	28	35	42	51	63	70
50	47	75	70	60	45	—	—	—	—
60	55	95	90	80	65	55	—	—	—
70	63	110	105	95	85	70	55	—	—
80	70	130	125	115	100	90	80	55	—
90	77	145	140	135	120	110	100	75	60
100	85	170	165	155	145	135	120	100	85
110	91	180	180	170	160	150	140	120	105
120	98	200	195	185	175	170	155	140	120

SOURCE: AASHTO, 1994, Ref. 1, Table X-6, p. 949

A comparison of the TxDOT design with the AASHTO design shows that at lower design speeds the TxDOT design may provide less length than the AASHTO design. If the TxDOT acceleration lane length is measured based on the AASHTO methodology (i.e., not including the 3.7 m to 0 m width taper section), the provided acceleration lane length would be the sum of the first two sections — 215 m. Compared with AASHTO, this length would be insufficient for a freeway design speed of 112 km/h and ramp design speeds of 72 km/h or less, a freeway design speed of 96 km/h and ramp design speeds of 56 km/h or less, or a freeway design speed of 80 km/h and ramp design speeds of 32 km/h or less. Therefore, the TxDOT design will not provide a sufficient length compared with AASHTO for 96 and 112 km/h freeways when the minimum ramp design speed of 50 percent of the freeway design speed is utilized. If half of the third section (93 m of the 186 m taper section) of the TxDOT design is included in the acceleration lane length and this total length is compared with AASHTO, the TxDOT design would satisfy the minimum requirements for the 80 and 96 km/h freeway design speeds, but not a 112 km/h freeway design speed. The entire taper length in the TxDOT design would need to be included to satisfy the required acceleration lane length for a 112 km/h freeway, according to AASHTO.

It should be noted that the preceding discussion, especially that of the TxDOT acceleration lane length being only 210 m, is a worst-case scenario. According to the AASHTO standards it may be possible to include more of the ramp length upstream of the TxDOT 75 m section as part of the acceleration lane length. The inclusion of more of the upstream length would be case specific, depending on the driver's ability to view the road (i.e., not being hampered by grades, obstructions, and curvature). Clearly some of the TxDOT designs would allow for inclusion of additional upstream length. Because the TxDOT standard design does not specifically address upstream design for all cases, it is not possible to make a general statement as to how much, if any, of the upstream ramp length should be included in satisfying the AASHTO recommended ramp acceleration lane lengths. Later in this report, both the TxDOT and AASHTO designs will be seen to be based on the same material.

Exit Ramps

The TxDOT exit ramp design follows the AASHTO design more closely than the acceleration lane design. The TxDOT standard exit ramp is of the taper type, with varying deceleration lane lengths dependent on ramp and freeway design speeds. In TxDOT Figure 4.61 (Figure 1.16, this report), a table of deceleration lane lengths for various freeway design speed/ramp design speed combinations is presented. This table is similar to Table 1.7, the AASHTO recommended deceleration lengths. Typically, the TxDOT and AASHTO recommended deceleration lane lengths are within ± 6 m of each other. The primary difference between the two design guides is that the AASHTO table provides ramp lengths for a mainline design speed of 48 km/h, whereas the TxDOT guide provides ramp lengths only for mainline speeds as low as 64 km/h. In addition, the TxDOT guide provides ramp lengths for 120 km/h and 128 km/h freeway design speeds, whereas the AASHTO guide provides ramp lengths only for freeway design speeds up to 112 km/h. Also included with the TxDOT deceleration lane lengths table are adjustments that should be made to the lengths to account for grades. These adjustments are the same as those recommended in the 1990 AASHTO guide. In a subsequent section of this report it will be shown that the AASHTO and TxDOT deceleration lane length tables are derived from the same source.

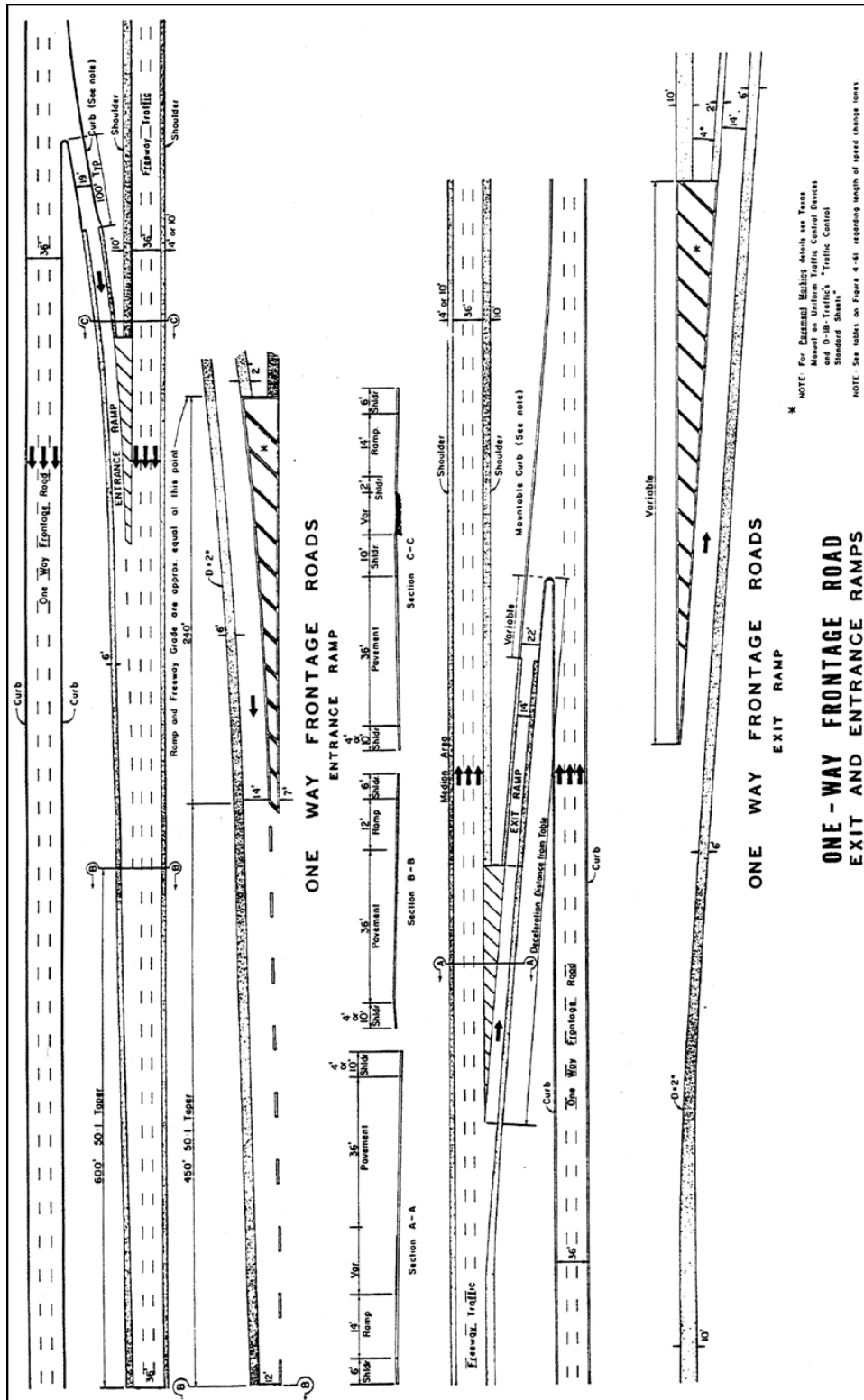

Figure 1.12. TxDOT one-way frontage road ramps

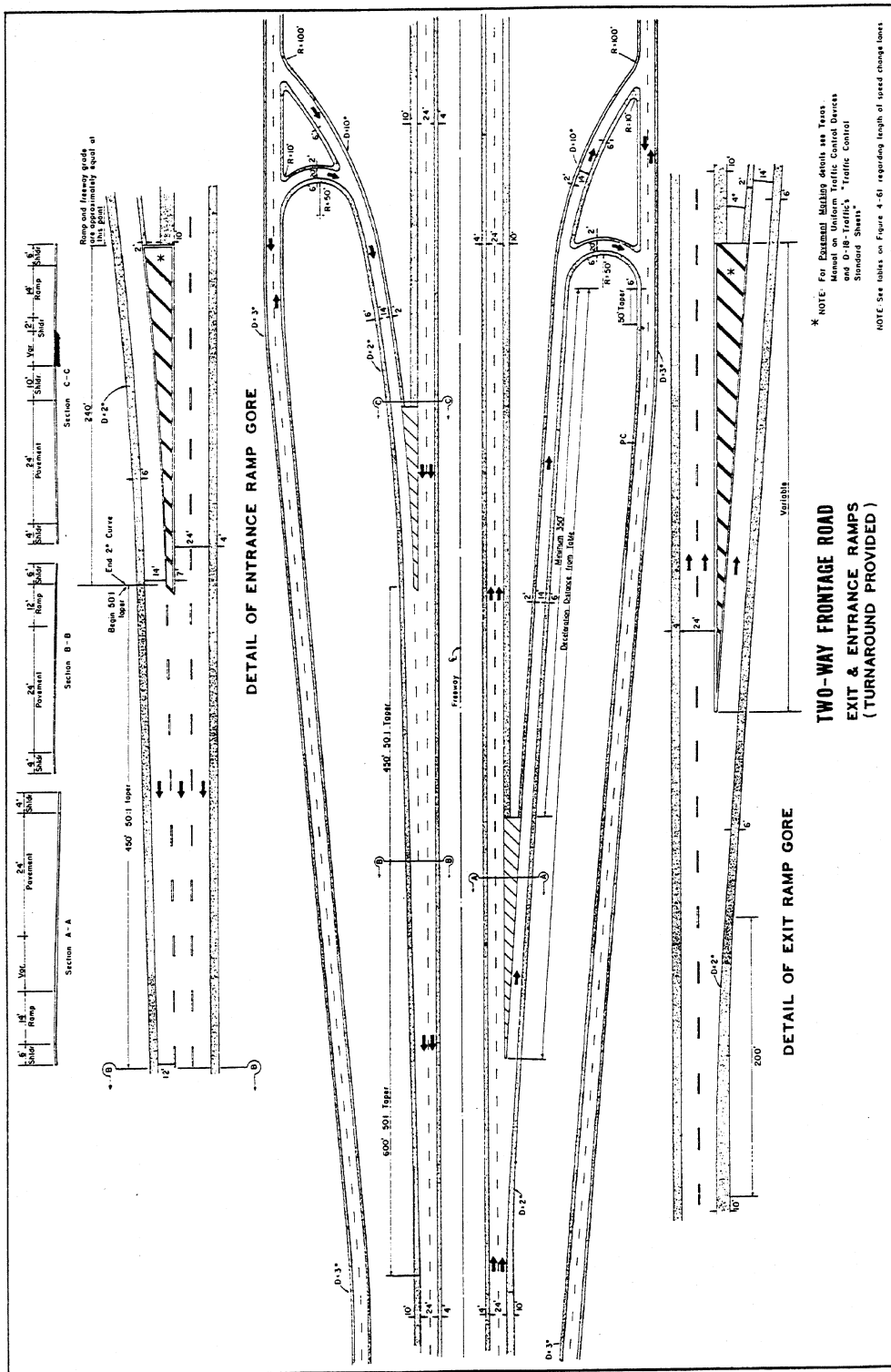

Figure 1.13. TxDOT two-way frontage road ramps with turnaround

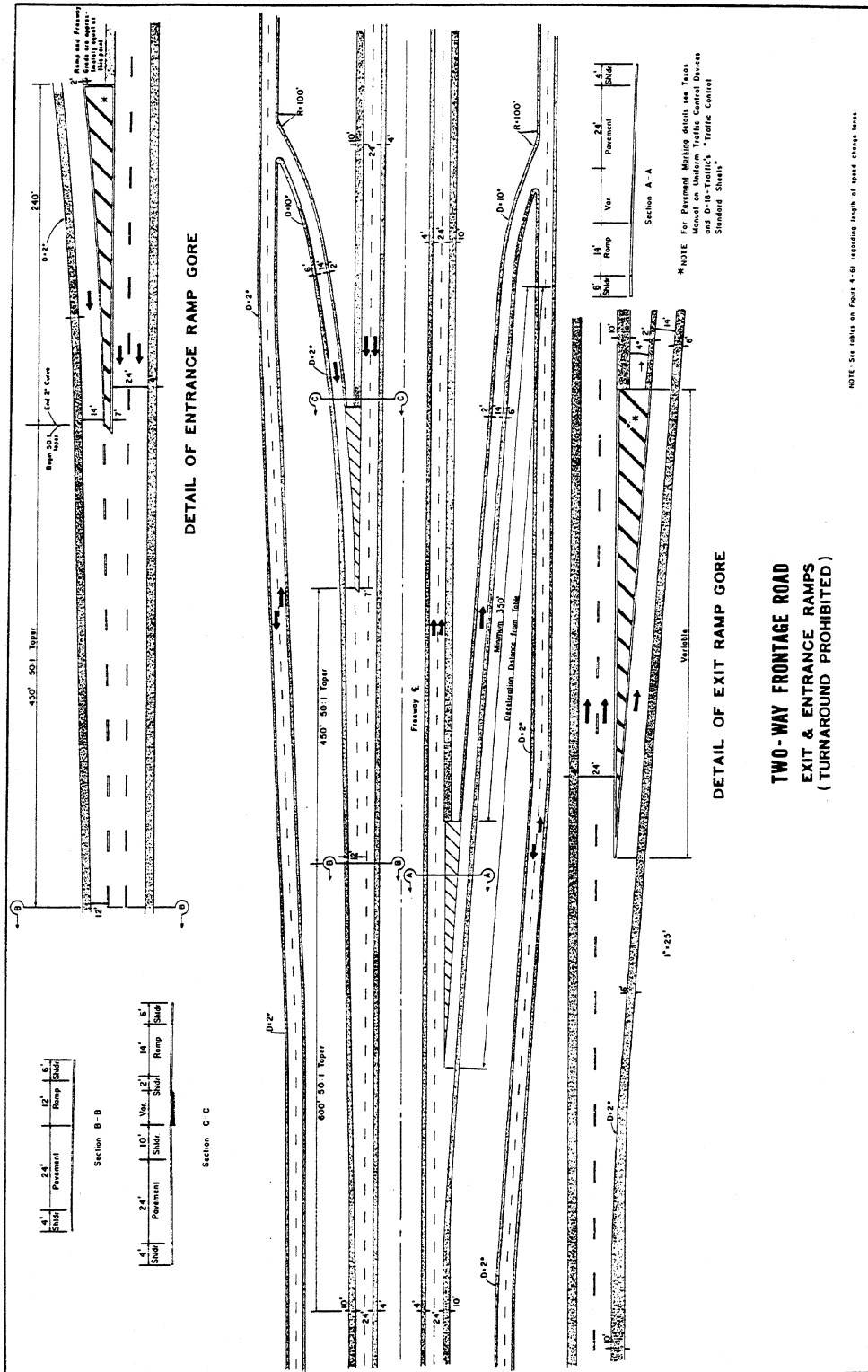

Figure 1.14. TxDOT two-way frontage road ramps without turnaround

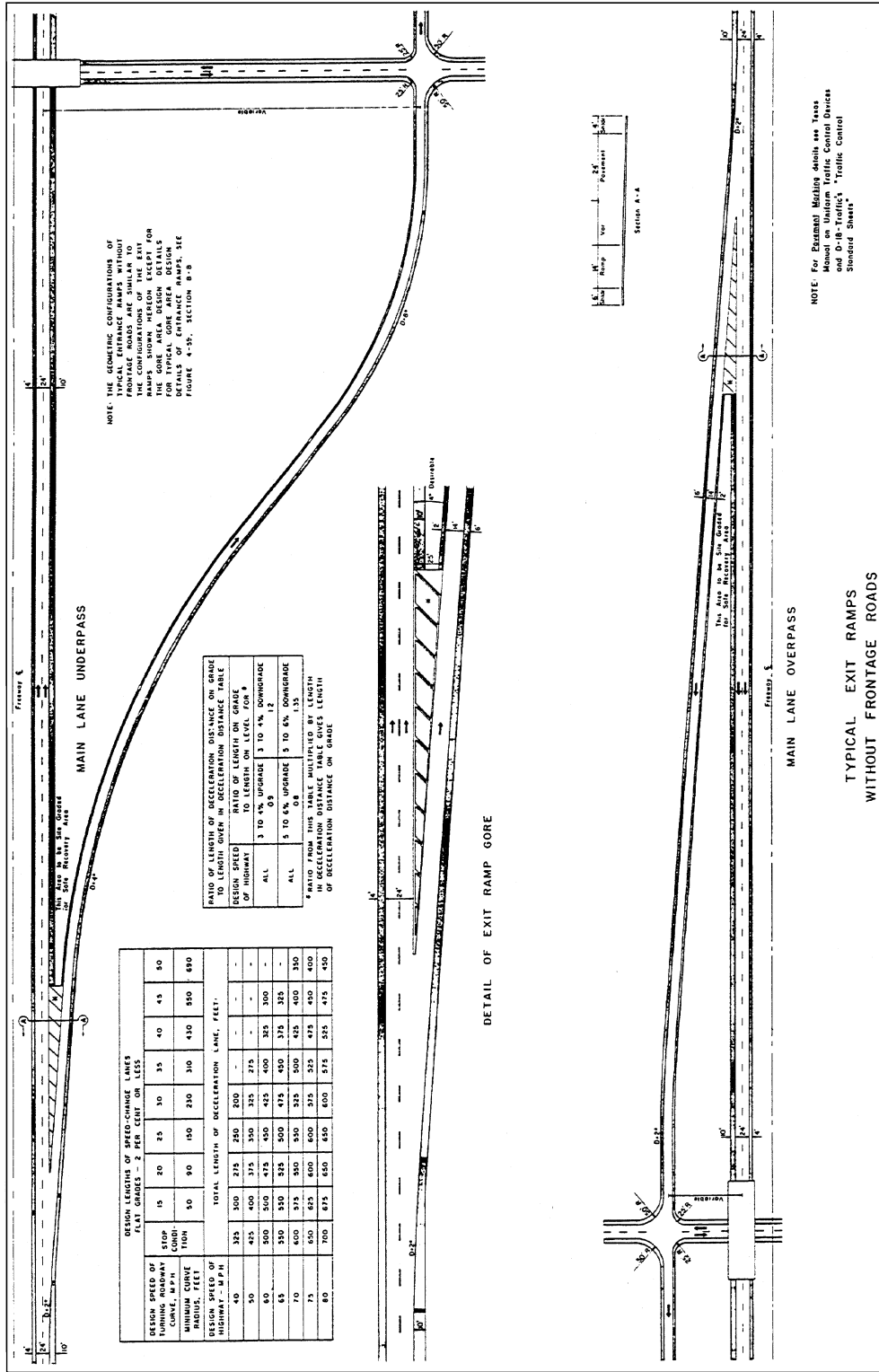

Figure 1.16. TxDOT typical exit ramps without frontage roads

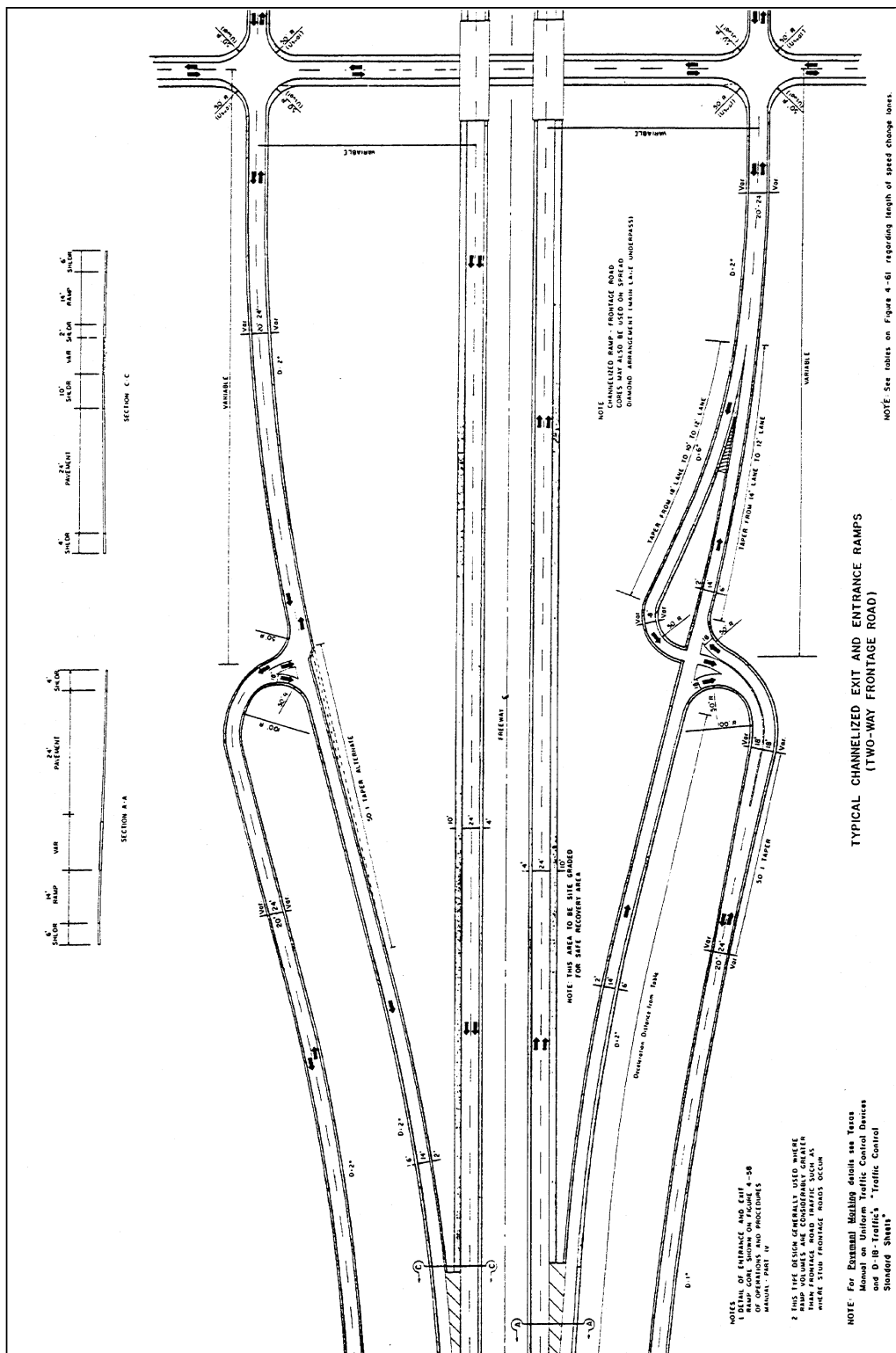

Figure 1.17. TxDOT channelized exit and entrance ramps

Other TxDOT Ramp Operations Issues

TxDOT utilizes two different approaches to restricting access on a controlled access facility. One method to control access involves the use of State of Texas police to control driveway access subject to certain conditions (H.B. 179 Planned Freeway). A second method (non-H.B. 179 Planned Freeway) is to control access solely by provision of frontage roads. It was discussed earlier that frontage road ramps may be used between interchanges or be incorporated into interchanges. To avoid operational problems, possibly including blockage at the merge point of the ramp and frontage road as a result of queue storage, TxDOT has developed exit-ramp-to-cross-street separation distance requirements. Figure 1.18, from the TxDOT design guide, shows the preferred minimum and absolute minimum separation distance between the frontage road, ramp merge, and cross street. This distance is based on accommodating weaving, braking, and storage for traffic.

DEVELOPMENT OF CURRENT RAMP DESIGN STANDARDS

Thus far, the reader has been presented with the elements of ramp design. Both TxDOT and AASHTO design standards have been reviewed, with similarities and differences highlighted. To better understand these designs and their applicability to today's traffic conditions, it is necessary to review the process by which these designs were developed. Unfortunately, neither the 1988 TxDOT manual nor the 1994 AASHTO manual provide much insight into the reasoning behind the recommended ramp design standards. A better source for the rationale inherent in both AASHTO's and TxDOT's current design is *A Policy on Geometric Design of Rural Highways* (1965), published by the American Association of State Highway Officials (AASHO, which has evolved into the current-day AASHTO). The guide is one in a series of continuing updates that has led to the 1994 AASHTO design manual. For clarification between the design manuals, this guide will be referred to as the 1965 AASHO guide, with the 1994 AASHTO design guide manual continuing to be referred to as the AASHTO design guide or 1994 AASHTO guide.

Design Speed

One of the most fundamental parameters affecting a design is the average design speed. Examination of AASHTO and TxDOT design standards shows that once a design speed is determined, the critical speed determining actual design features (e.g., lane lengths, curve radii) is the assumed average running speed of vehicles for that design speed. This average running speed is lower than the design speed and may be seen in Table 1.1, where the minimum stopping sight distance for particular design speeds is based on an assumed design speed. Average running speeds are based on low-volume conditions, meaning that the characteristics of the roadway should be governing vehicle speeds and not interactions with other vehicles. The average running speeds used in the 1988 TxDOT manual and the 1994 AASHTO manual are first seen in the 1965 AASHO guide, with these speeds apparently

based on studies from the fifties and sixties. The earlier 1954 AASHO guide suggests running speeds that are significantly lower than those of the 1965 guide.

A question exists as to whether these assumed average running speeds are still accurate under today's conditions. One 1992 study, *Speed Estimates for Roadway Design and Traffic Control* (31), suggests that the speed estimates used are significantly below the actual speeds. One estimate indicated that as much as 90 percent of observed traffic exceeded posted speed limits, which are often near the assumed low-volume running speed. Additional evidence in support of the growing belief that the assumed average running speeds are unrealistic may be found in the methodology of NCHRP 3.35, *Speed-Change Lanes Final Report*. In this study the speed used to determine the required length of a speed-change lane was the design speed itself, not the AASHTO running speed.

One study performed in Canada in 1968 (32) observed speeds on a series of exit ramps at the point of maximum curvature and compared these speeds to the design speed of the ramp. Because these were existing ramps, design speeds were determined according to superelevation rates and curve radii of the 1965 AASHO guide. Table 1.8 shows the results of these observations.

While for all six interchanges the 50th percentile speed is less than the design speed, it is seen that the 85th percentile speed at four of the six ramps was observed to be at or above the design speed. This is critical because design is often based on the 85th or 90th percentiles, not the 50th percentiles, so as to create designs that are adequate for the majority of drivers. It also should be realized that the two ramps where the observed speed at the 85th percentile did not reach or exceed the design had design speeds of 91 and 104 km/h, which exceeded the 80 km/h freeway speed limit at the time of the study.

Guide Values for Ramp Design Speed

Discussed earlier was AASHTO Table X.1 (Table 1.3, this report), which provides guidelines on ramp design speeds. One of the earliest recommendations for design speed of ramps may be found in *Proposed Design Standards for Interregional Highways*, 1944 (30). In this document the recommendation was that "all ramps and connections would be designed to enable vehicles to leave and enter the highway at 0.7 of the highway's design speed." Over time, changes have been made to this recommendation, resulting in Table 1.3. This table in its current form first appeared in the 1984 manual. Before this, the recommendations were slightly different, with AASHTO having guides only for desirable and minimum ramp design speeds, not for the three ranges (upper, middle, and lower) as seen today. Figure 1.19 shows the progression of the AASHTO recommendations from the original 1954 design guide to the 1990 guide. While in all cases the upper or desirable recommended ramp design speed is approximately the average low-volume running speed for the freeway design speed, the minimum and middle ranges do not appear to have a correlation with a traffic characteristic or design parameter. No literature has been found that reveals the source of these recommendations or reason for the changes in each subsequent update.

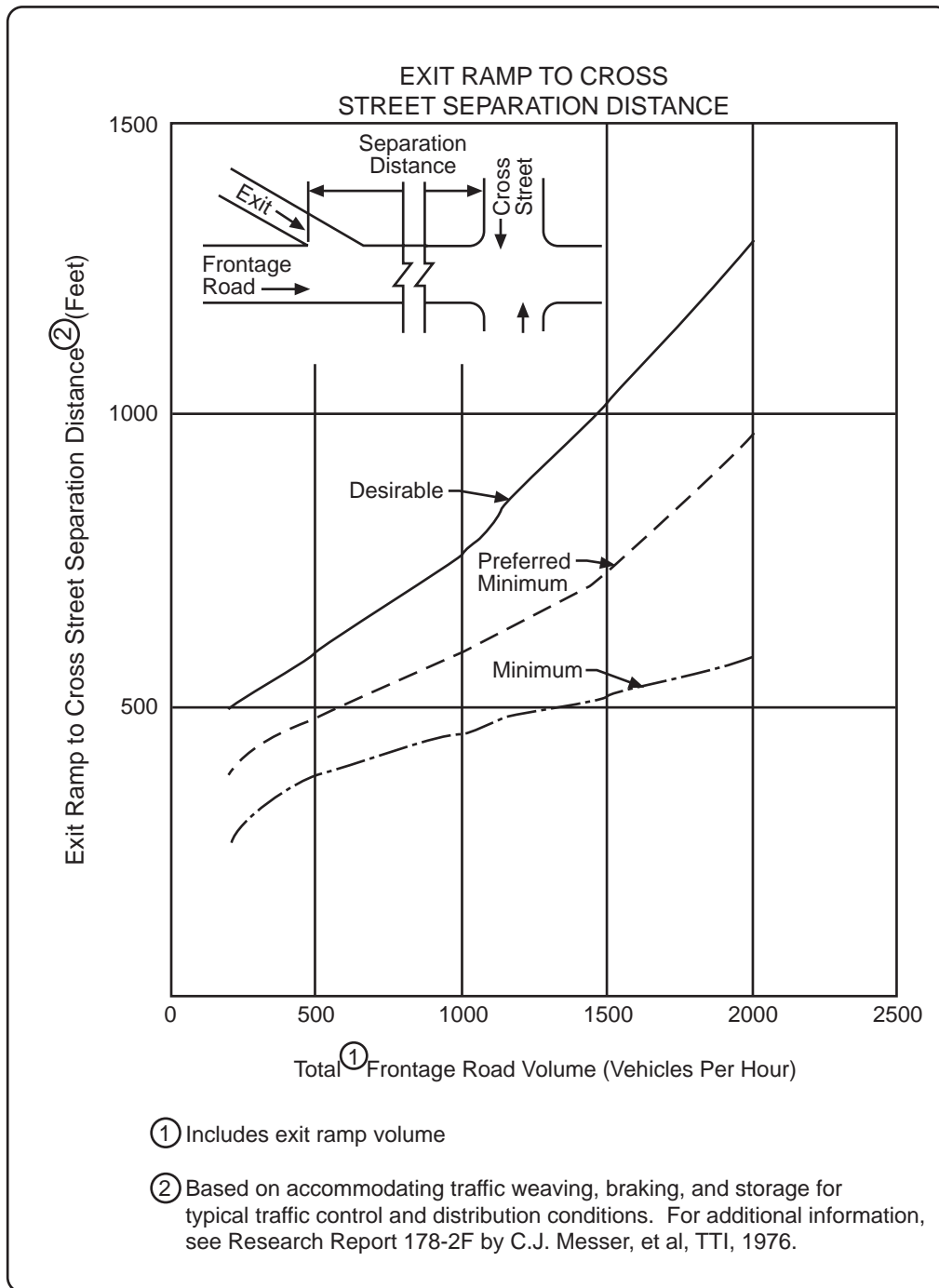

Figure 4-46. Refers to Paragraph 4-602(A)6
 (Source: Figure 4-46, Ref. 5, p. 4-89)

(Source: Figure 4.46, Ref. 5, p. 4.89)

Figure 1.18. TxDOT exit ramp-to-cross street separation

Table 1.8. Observed exit ramp speeds

Intersection	Design Speed of Exit (mph)	Observed Speeds (mph) at Points of Maximum Curvature				
		0 Percentile	15 Percentile	50 Percentile	85 Percentile	100 Percentile
Dixon Road	57.0	22.5	35.8	43.0	48.7	62.5
Islington Ave.	36.0	20.0	26.3	29.9	39.8	42.5
Weston Road	28.5	15.0	21.6	24.9	30.7	45.0
Keele Street	65.0	17.5	28.1	35.0	39.4	50.0
Dufferin Street	32.0	0*	18.1*	25.7*	31.7*	42.5*
		12.5**	21.7**	26.3**	31.8**	42.5**
Avenue Road	32.0	20.0	28.8	32.8	37.7	45.0

*Includes delayed vehicles

**Delayed vehicles omitted

Source: *Vehicle Operating Characteristics on Outer Loop Deceleration Lanes of Interchanges*, O.J.H.R.P. Report No. 43, March 1968, Table 6, pp. 57.

The 1965 AASHO guide presentation of the design of speed-change lanes provides more information than later design guides on the derivation of design standards (the 1954 AASHO guide also provides much of what is found in the 1965 AASHO guide). The 1965 manual defines a speed-change lane as “an auxiliary lane, including tapered areas, primarily for the acceleration or deceleration of vehicles entering or leaving the through traffic lanes. The term speed-change lane, deceleration lane, or acceleration lane, as used herein, applies broadly to the added pavement joining the traveled way of the highway with that of the turning roadway and does not necessarily imply a definite lane of uniform width.” While not clearly defined as such, the 1965 AASHO guide does begin to recognize the two major competing speed-change lane designs, namely, parallel and taper. The guide distinguishes between the benefits of the two by stating that drivers prefer to use a direct rather than a reverse path (i.e., taper design), though under heavy traffic volumes there is a tendency for drivers to utilize more of the deceleration lane, following a reverse curve path (i.e., parallel design). For both deceleration and acceleration lanes there is a clear, but not directly stated, favoring of the taper type design.

1954 AASHO

Highway design speed, mph	30	40	50	60	70
Ramp design speed, mph					
Desirable	25	35	40	45	50
Minimum	15	20	25	30	30
Corresponding minimum radius, feet					
Desirable	150	300	430	550	690
Minimum	50	90	150	230	230

Source: Table IX-2, 1954 A Policy on Geometric Design of Rural Highways, pp. 393

1965 AASHO

Highway design speed, mph	30	40	50	60	65	70	75	80
Ramp design speed, mph								
Desirable	25	35	45	50	55	60	60	65
Minimum	15	20	25	30	30	30	35	40
Corresponding minimum radius, feet								
Desirable	150	300	550	690	840	1040	1040	1260
Minimum	50	90	150	230	230	230	300	430

Source: Table IX-2, 1965 A Policy on Geometric Design of Rural Highways, pp. 531

1973 AASHTO

Highway design speed, mph	30	40	50	60	65	70
Ramp design speed, mph						
Desirable	25	35	45	50	55	60
Minimum	15	20	25	30	30	30
Corresponding minimum radius, feet						
Desirable	150	300	550	690	840	1040
Minimum	50	90	150	230	230	230

Note: Ramp design speeds above 30 mph seldom are applicable to loops

Source: Table J-1, 1973 A Policy on Design of Urban Highways and Arterial Streets, pp. 545

1984 AASHTO

Highway Design Speed (mph)	30	40	50	60	65	70
Ramp Design Speed (mph)						
Upper Range (85%)	25	35	45	50	55	60
Middle Range (70%)	20	30	35	45	45	50
Lower Range (50%)	15	20	25	30	30	35
Corresponding Minimum Radius (ft)	SEE TABLE III-6					

Source: Table X-1, 1984 A Policy on Geometric Design of Highways and Streets, pp. 1012

1990 AASHTO

Highway Design Speed (mph)	30	40	50	60	65	70
Ramp Design Speed (mph)						
Upper Range (85%)	25	35	45	50	55	60
Middle Range (70%)	20	30	35	45	45	50
Lower Range (50%)	15	20	25	30	30	35
Corresponding Minimum Radius (ft)	See Table III-6					

Source: Table X-1, 1990 A Policy on Geometric Design of Highways and Streets, pp. 960

Figure 1.19. Historical AASHTO ramp design speed recommendations

The improved 1990 AASHTO guide highlights the differences between the two design types, discusses design considerations, and provides some clarification in measuring and providing the speed-change lane with the proper length once chosen. However, an examination of the 1965 AASHO guide leads to the conclusion that most design values are the same as those in the 1990 AASHTO guide. Interestingly, many of the design values found in the 1988 TxDOT design guide are also from the 1965 AASHO guide, whereas a simple comparison of the 1990 AASHTO design guide with the 1988 TxDOT guide may lead one to believe that certain design values were developed separately. To demonstrate and provide insight into both the current TxDOT and AASHTO design standards, the rationale behind the design of the taper and deceleration and acceleration lanes will be presented.

Taper Section

One of the first design aspects covered in the speed-change lane design is taper; that is, the taper at the end (or beginning) of the speed change lane — not to be confused with the taper type speed-change lane design. While current AASHTO design recommends a taper of 91 m for entrance ramps and 76 m taper for exit ramps (parallel type, design speeds up to 112 km/h) and TxDOT utilizes a taper section of 183 m in acceleration lane design, the 1965 guide recommended variable taper lengths according to Table 1.9.

These taper lengths were based on passing practices on two-lane highways as determined in a 1941 study (8). This study found that depending on traffic conditions a passing vehicle would shift laterally one lane in 2.6 to 4.1 seconds. From this it was assumed that the time required for a driver to shift from a through lane to a speed-change lane was 3 seconds minimum to 4 seconds desirable, leading to a value of 3.5 seconds for design. The taper length for a particular design speed is then simply based on the distance traveled during 3.5 seconds at the average running speed. Thus, a simplification of this table would be for a 91 m taper for speeds under 112 km/h, as now used by AASHTO for parallel type entrance ramps. AASHTO utilizes a taper length for design speeds closer to 96 km/h for parallel type exit ramps. An explanation for the different taper length used in the 1990 AASHTO was not found in reviewing the literature. The source for the TxDOT taper length will be discussed in the acceleration lane section.

While the 3.5 second time to shift lanes is based on a 1941 study, this movement has been studied more recently. In the NCHRP report, *Speed-Change Lanes* (1989), a study of the distribution of times observed for a driver to steer from the acceleration lane completely onto the adjacent freeway lane was completed. This study found approximately 1.25, 1.75, and 3.24 seconds to be the 15th, 50th, and 85th percentile speeds, respectively, with an average of 2.3 seconds. These values, together with the likelihood that vehicle and driver characteristics have changed since the 1941 study, lead to the conclusion that taper design clearly needs to be revisited as a step toward possibly updating the design standards.

Table 1.9. AASHO 1965 guidance for lengths of taper for use in conjunction with full-width speed-change lanes

Highway design speed (mph)	30	40	50	60	65	70	75	80
Average running speed (mph)	28	36	44	52	55	58	61	64
Minimum length (ft)	145	185	225	270	285	300	315	330
Length of taper (rounded)	150	190	230	270	290	300	315	330

Source: Table VII-9, *A Policy on Geometric Design of Rural Highways*, AASHO, 1965 (6)

Deceleration Lanes

The 1965 AASHO guide bases the deceleration lane length on three factors: “(a) the speed at which drivers maneuver onto the auxiliary lane; (b) the speed at which drivers turn after traversing the deceleration lane; (c) the manner of decelerating or the deceleration factors.”

The first factor — the speed at which drivers maneuver onto the auxiliary lane — is based on the assumption that when shifting into the deceleration lane most drivers travel at a speed no greater than that of the low-volume average running speed. The small percentage of drivers who travel at higher speeds are assumed to be alerted to the exit by signs and, in response, are assumed to slow down to the running speed by the beginning of the taper.

The second factor — the speed at which the drivers turn after traversing the deceleration lane — is assumed to be the running speed of the sharp or controlling curve of the ramp proper. Determination of this running speed is based on Table VII.3, page 325, in the 1965 guide. This table is exactly the same as Table III.17 in the 1990 guide and has been previously discussed in the presentation of ramp design (Table 1.5 in this report). The difference between the average running speeds on the freeway and the controlling curve is then taken to be the speed differential used in the determination of the deceleration lane length.

The third factor — the manner of deceleration or the deceleration factors — is based on general observations and several limited studies. It was determined that the deceleration process occurs in two steps: deceleration in gear and deceleration while braking. The design values for these rates are based on several studies conducted primarily in the late thirties (7, 10, and 11). A discussion of these studies and the appropriateness of continuing to utilize their rates in today’s designs is reserved until after the discussion of acceleration lanes.

For design purposes deceleration in gear is assumed to occur for 3 seconds. The distance traveled during this time is based on deceleration characteristics determined in *Speed-Change Rates for Passenger Vehicles*, of 1938 (7). Figure 1.20, taken from the 1965 AASHO guide and based on this study, is utilized in determining the distance traveled and speed reached when beginning from some initial speed and decelerating in gear for 3

seconds. For speed-change lane design, the initial speed is the average running speed of the freeway.

The second portion of the deceleration lane length — deceleration while braking — is based on the 1938 study *Acceleration and Deceleration Characteristics of Private Passenger Vehicles* (11) and the 1940 study *Deceleration Distances for High-Speed Vehicles* (10). The first study (11) actually is for deceleration characteristics while approaching a stop sign, but it was assumed for the design of the speed-change lanes that the deceleration rates would be characteristic of those for approaching the turning roadway. From these studies a “comfortable” overall rate of deceleration while braking from a speed of 112 km/h was found to be approximately 2.8 m per second (10), and the rate is assumed to decrease as the speed decreases (11) to approximately 1.8 m per second at 48 km/h. These “comfortable” rates were assumed acceptable for design standards. Figure 1.21, taken from the 1965 AASHO guide, shows the distance traveled during braking. For this figure the initial speed is the speed reached at the end of the 3 second deceleration in gear and the final speed is the average running speed for the turning roadway.

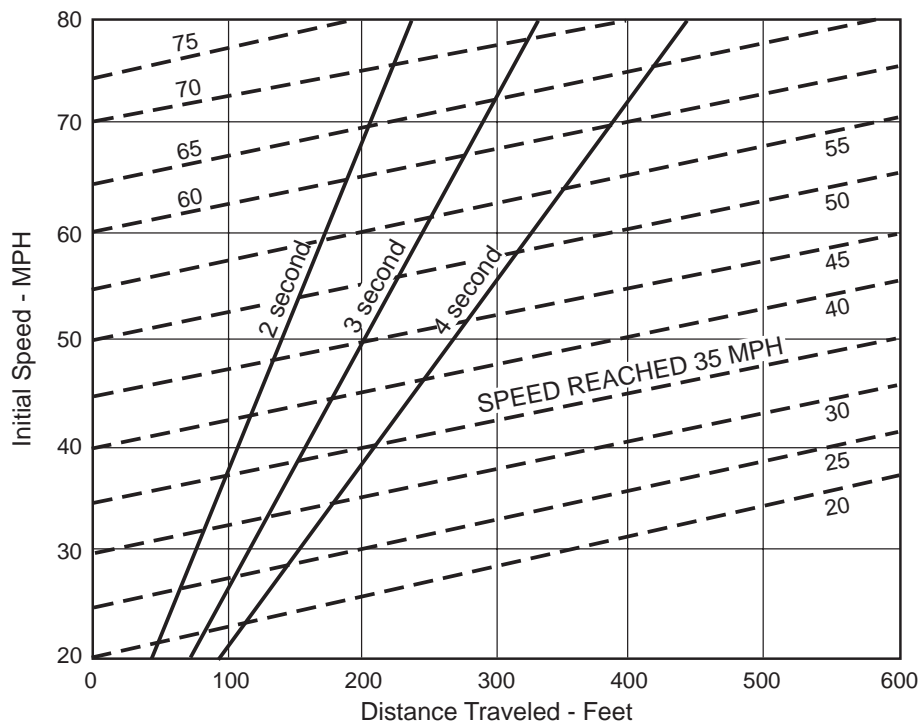

Distance Traveled During Deceleration in Gear Without Use of Brakes

- A -

(Source: Figure VII.15, Ref. 6, p. 350)

Figure 1.20. AASHO 1965, distance traveled during deceleration

To summarize, the length of the deceleration lane is calculated in the 1965 AASHO by assuming that a vehicle 1) is traveling at an initial speed at the beginning of the deceleration lane equal to the average running speed of the highway, 2) decelerates in gear for 3 seconds traveling a distance that may be determined from Figure 1.20, and 3) then decelerates while braking, at a rate according to Figure 1.21, to the average running speed of the turning roadway. According to the 1965 AASHO guide, “lengths based on these assumptions permit a driver to decelerate comfortably and safely when he approaches the deceleration lane at the average running speed of the highway.”

As a final point it should be understood that this design is based on passenger vehicle operation. While the 1965 AASHO guide recognizes that trucks require a longer deceleration distance for the same speed differential, it is assumed that “longer lanes are not justified because average speeds of trucks are generally less than those of passenger cars.”

Based on the methodology discussed, Figure VII.16 is presented in the 1965 AASHO manual and reproduced in this report as Table 1.10. This presentation is partially unnecessary because a comparison of this table and Table 1.7 (AASHTO 1990 Table X.6) reveals these tables have exactly the same design values. The only numerical difference is that Table 1.10 (1965 version) gives design values for highway design speeds of 120 and 128 km/h, whereas Table 1.7 (1990 version) provides design values only as high as 112 km/h.

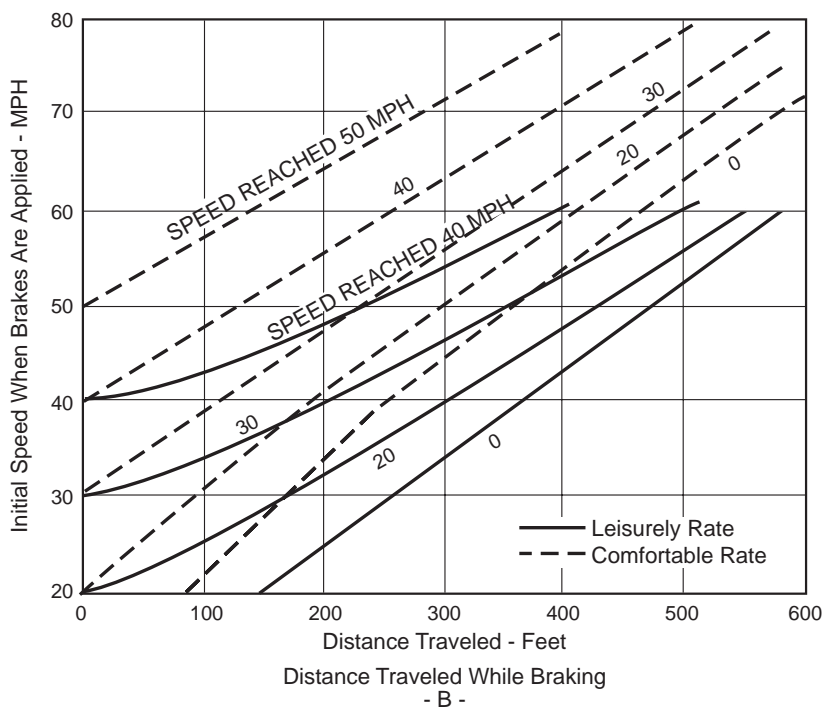

(Source: Figure VII.15, Ref. 6, p. 350)

Figure 1.21. AASHO 1965, distance traveled while braking

There is, of course, a reason for presenting both versions. An examination of the speed-change lane drawings, intended to assist the designer in properly applying the values, shows a critical difference in the methodology of applying the design lengths. The 1965 AASHO guide assumes the taper to be part of the total speed-change lane length, whereas the 1990 AASHTO guide treats the taper as an additional length. This means that while not altering any of the fundamental data on which the lengths are derived (i.e., average running speeds, acceleration, and deceleration rates), the 1990 AASHTO guide deceleration lanes are essentially 91 m (typical taper length) longer than the 1965 AASHO lengths. The primary differing assumption between the two manuals seems to be that the 1965 AASHO guide assumes that deceleration in gear occurs while the vehicle shifts from the freeway lane to the deceleration lane, while the 1990 AASHTO guide assumes deceleration in gear does not begin until the vehicle has completely entered the deceleration lane. This shift in what is assumed appears to have occurred between the 1965 AASHO guide (the blue book) and the 1973 AASHTO guide (the red book [16]). In reviewing the literature for this report, no literature has been discovered thus far that explains the rationale behind this change, with the red book actually referring the reader to the blue book for an explanation of how the speed-change lane design values are derived.

Table 1.10. AASHO 1965, lengths for deceleration lanes

Highway Design Speed, MPH (V)	Average Running Speed, MPH (V_a)	L = Length of Deceleration Lane – Feet for Design Speed of Exit Curve – MPH (V^1)								
		Stop Condition	15	20	25	30	35	40	45	50
		For Average Running Speed on Exit Curve – MPH (V_a)								
		0	14	18	22	26	30	36	40	44
30	28	235	185	160	140	---	---	---	---	---
40	36	315	295	265	235	185	155	---	---	---
50	44	435	405	385	355	315	285	225	175	---
60	52	530	500	490	460	430	410	340	300	240
65	55	570	540	530	490	480	430	380	330	280
70	58	615	590	570	550	510	490	430	390	340
75	61	660	630	610	590	560	530	470	440	390
80	64	700	680	660	640	610	580	530	490	450

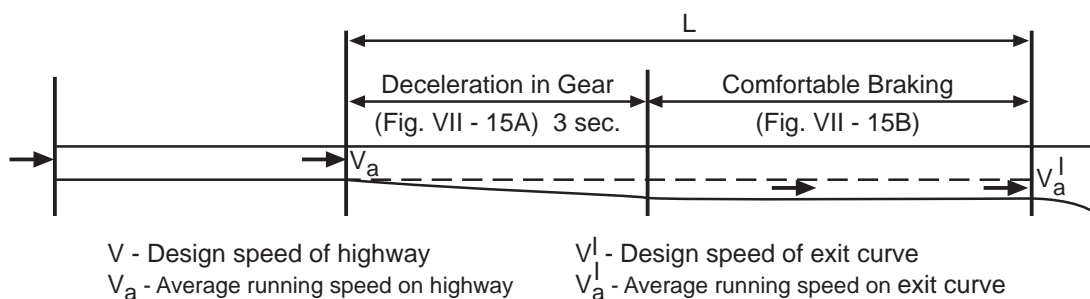

(Source: Figure VII.16, Ref. 6, p. 353)

Table VII.10 from the 1965 AASHO blue book is shown as Table 1.11 in this report. This table — a rounding of the values of Table 1.10 — was developed for determining speed-change lane lengths for design. This rounded version of the deceleration lane length for design was dropped in subsequent versions of the guide (1973, 1984, and 1990), with the later versions using the raw numbers found in Table 1.10. Interestingly, the deceleration length table in Figure 4.61 in the TxDOT manual (Figure 1.16 in this report) is exactly the same as the rounded version of the AASHO 1965 guide design lengths. This revelation provides an important link between the TxDOT and AASHTO guides that is not readily apparent in the comparison of the latest versions of these guides; that is, the TxDOT values are based on the same studies and methodology as the current AASHTO values. At this time, there has been no literature found to explain why AASHTO ceased using the rounded table or why TxDOT did not change to the raw design lengths along with AASHTO.

Acceleration Lanes

As with the deceleration lanes, the 1965 AASHO guide offers little guidance in choosing between the parallel and taper type speed-change lanes. There appears to be an unstated assumption that most acceleration lanes will be of the taper type (at a 50:1 taper) with the guide providing only a brief mention that some designers may prefer a parallel acceleration lane with a more acute taper at the end. The 50:1 taper is readily seen as that carried into the TxDOT standard designs (Figures 1.12 through 1.17) and the 1990 AASHTO taper type designs, with the exception of AASHTO recommending a range from 50:1 to 70:1.

The 1965 AASHO guide bases the length of the acceleration lane on several factors: “(a) the speed at which drivers merge with through traffic; (b) the speed at which drivers enter the acceleration lanes; and (c) the manner of accelerating or the acceleration factors . . . and may depend on the relative volumes of the through and entering traffic.” Many of the rationales and assumptions used are similar to those of the deceleration lanes, allowing for this review of acceleration lanes to be less detailed.

For the first and second factors, the 1965 AASHO guide states that a satisfactory merging operation would be achieved by a vehicle on the acceleration lane entering the freeway through lane at a speed 8 km/h less than the average running speed of the freeway. Also, this vehicle is assumed to enter the acceleration lane at a speed equal to the controlling speed of the ramp proper. Therefore, the speed differential for determining the length of the acceleration lane is the difference between the average running speed of the freeway, less 8 km/h, and the average running speed of the controlling curve on the ramp proper. It will be seen when discussing other modeling approaches that the 8 km/h incremental difference assumed by AASHO may not hold. For example, it has been suggested that drivers do not merge in response to some threshold speed differential, but instead merge at any speed differential, dependent on some other element such as vehicular angular velocity (9) (vehicular angular velocity is explained in a later section of this report).

Table 1.11. AASHO 1965, design length for speed-change lanes

All Main Highways Flat Grades - 2 Percent or Less										
Design speed of turning roadway curve, mph		Stop Condition	15	20	25	30	35	40	45	50
Minimum curve radius, feet			50	90	150	230	310	430	550	690
Design Speed of Highway, mph	Length of taper, feet	Total length of DECELERATION lane, including taper, feet:								
40	190	325	300	275	250	200				
50	230	425	400	375	350	325	275			
60	270	500	500	475	450	425	400	325	300	
65	290	550	550	525	500	475	450	375	325	
70	300	600	575	550	550	525	500	425	400	350
75	315	650	625	600	600	575	525	475	450	400
80	330	700	675	650	650	600	575	525	475	450
Design Speed of Highway, mph	Length of taper, feet	Total length of ACCELERATION lane, including taper, feet:								
40	190		325	250	225					
50	230		700	625	600	500	400			
60	270		1125	1075	1000	900	800	600	400	
70	300		1550	1500	1400	1325	1225	1000	825	575

NOTE: Uniform 50:1 tapers are recommended where lengths of acceleration lanes exceed 1300 feet, or where design speeds exceed 70 mph, or elsewhere if appropriate and space permits.

SOURCE AASHO, 1965 A Policy on Geometric Design of Rural Highways, Table VII-10, page 351

As with deceleration rates, the manner of acceleration or the acceleration rates are determined primarily from studies completed in the late thirties. These studies produced both estimates of maximum and normal acceleration rates. Maximum acceleration rates were found to vary between approximately 4 km/h/s (kilometers per hour per second) at 48 km/h and 1.6 km/h/s at 112 km/h. Normal acceleration rates of drivers were stated to be difficult to measure and found to vary considerably, dependent on individual driver characteristics. Curve A in Figure 1.22 represents the acceleration rates used in the calculation of acceleration lane lengths. These rates are approximately 60 percent of full acceleration rates (Curve C) determined during the same study. In this study the normal acceleration rate was observed to decrease in a nonlinear fashion as speed increased.

Figure 1.23, based on the acceleration rates from the 1938 study, allows for the determination of the acceleration lane lengths. A table was also produced for various combinations of freeway and ramp design speeds. This table is not reproduced for this

report, as it is exactly the same as the table for the determination of acceleration lanes in the 1990 AASHTO guide (Table 1.6, this report). As with the deceleration lane lengths, the 1965 AASHO manual provided a rounded set of values to be used with a design that was subsequently dropped in later design manuals. These values may be seen in Table 1.11 included in the deceleration lane section of this report.

Two additional points should be re-emphasized. First, it is important to realize that the 1965 AASHO design considers the taper to be part of the speed-change lane length. Therefore, while design values are the same numerically in the 1965 and 1990 manuals, the 1990 measurement method will result in longer acceleration lane lengths. Secondly, the designs are based on the acceleration characteristics of passenger cars. The 1965 AASHO guide addresses this issue by stating that required truck acceleration distances would be "...entirely out of reason. A slower entry of trucks and buses is unavoidable and generally accepted by the traveling public." Nonetheless, it is further recommended that where high volumes of trucks are anticipated, longer acceleration lanes be utilized or other special treatments considered.

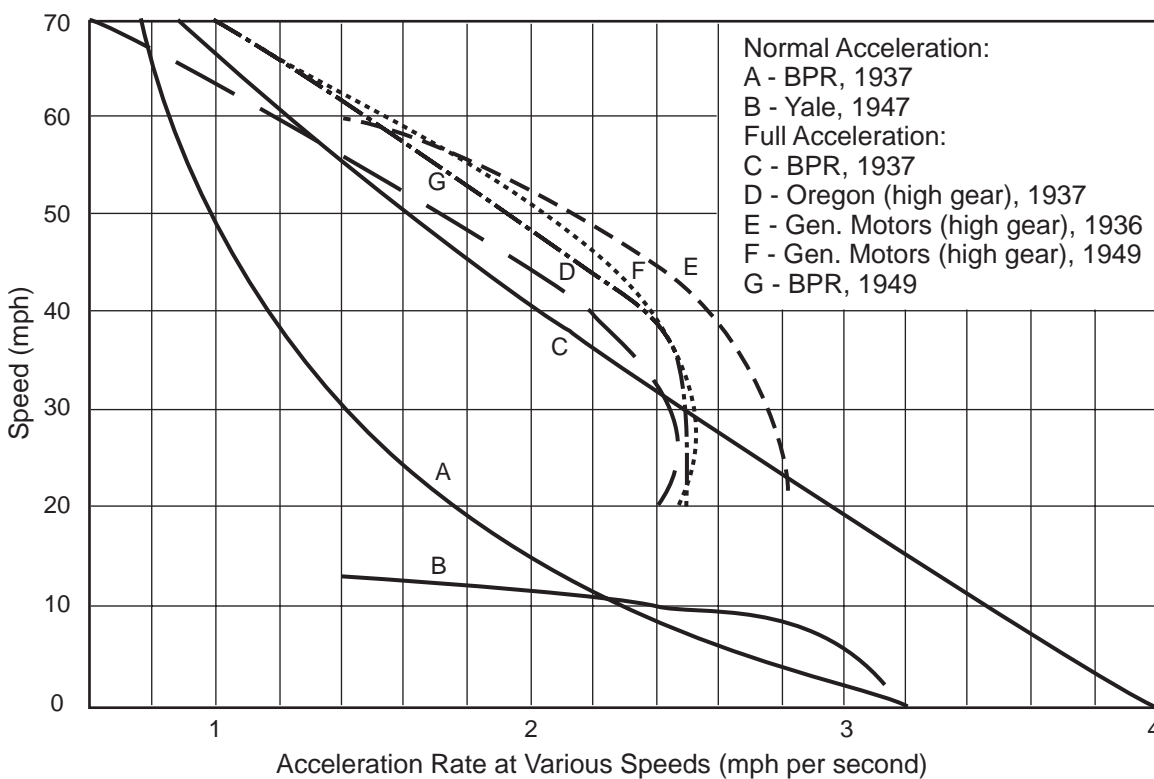

(Source: Figure VII.17, Ref. 7, p. 355)

Figure 1.22. Acceleration rates for passenger vehicles

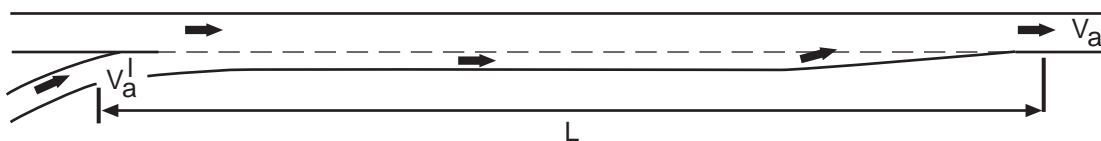
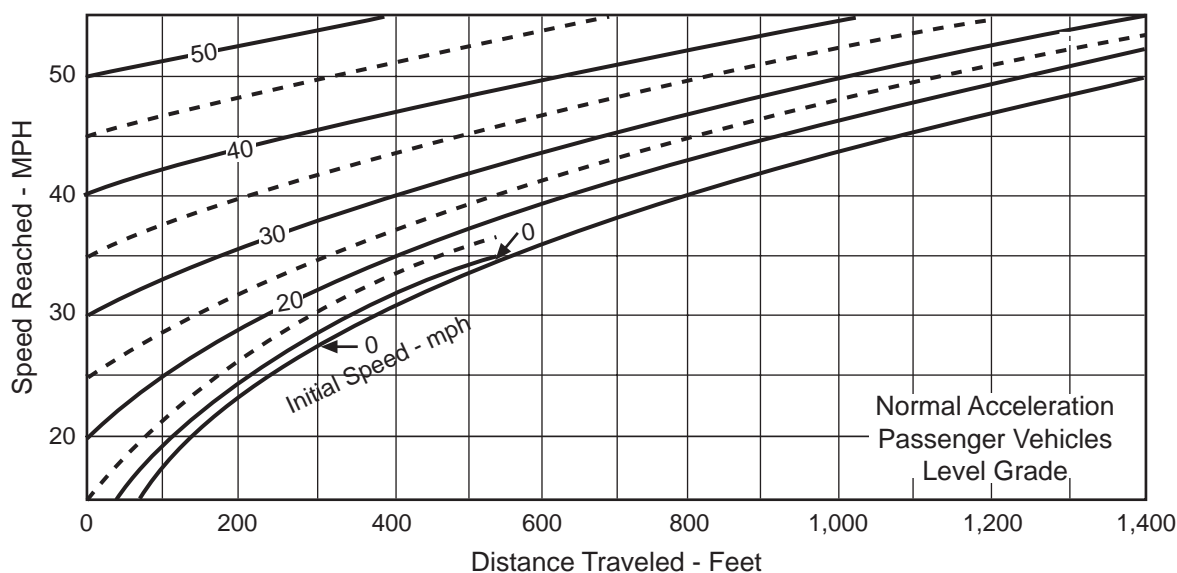

(Source: Figure VII.18, Ref. 6, p. 356)

Figure 1.23. Normal acceleration on level grades

As with deceleration lanes, it is possible to connect the 1965 AASHO directly to both the 1990 AASHTO guide and the 1988 TxDOT guide. Already it has been seen that the acceleration lane lengths from the 1965 AASHO guide are utilized in the 1990 AASHTO guide. It is logical then to assume that there is also a connection between the 1988 TxDOT design guide acceleration lane length and the earlier AASHO work. An examination of TxDOT's standard designs reveals that all TxDOT acceleration lanes for single-lane ramps are designed in the same general manner utilizing a taper type design. The standard design consists of three sections: 1) a 73 m section upstream of the meeting point of the right lane of the freeway and the left lane of the ramp, 2) a 137 m section tapered at 50:1 from the end of the 73 m section to where the right edge of the ramp and freeway lanes are 3.7 m apart, and 3) a 183 m taper section at 50:1. This leads to a total acceleration lane length, including taper, of 393 m.

Compared with the 1965 rounded acceleration length table, 393 m satisfies all design lengths for freeway design speeds of 80 and 96 km/h; in addition, 393 m falls between ramp

design speeds of 48 and 56 km/h for a 112 km/h freeway design speed. Recall that the minimal design speed of a ramp is to be 50 percent of the freeway design speed (i.e., 56 km/h for a 112 km/h freeway): This supports the assumption that the TxDOT standard design is based on the 1965 AASHO methodology. It would seem that TxDOT design officials decided to utilize one standard design that satisfied all acceptable ramp/freeway design speed combinations. Accordingly, for any situation other than the 112 km/h freeway and 56 km/h ramp (the maximum acceleration lane length case), TxDOT's design would be conservative according to the 1965 methodology, utilizing a longer length than AASHO recommended.

To further connect the TxDOT standard design to the 1965 AASHO methodology, a clarification of the taper section is in order. As noted earlier, the 1965 AASHO guide utilized varying lengths of taper sections, but in the taper type acceleration lane design the guide recommends a 50:1 taper for the speed-change lane. Therefore, at the end of the acceleration lane, the taper section in which the lane is reduced from a 3.7 m to 0 m width would be equal to 3.65 m multiplied by 50, or 183 m — exactly what is used in the TxDOT design. This is approximately double the taper length used in a parallel type design.

Acceleration and Deceleration Rates

As seen, the values used for the acceleration and deceleration rates directly influence the speed-change lane length. Owing to the fundamental importance of acceleration and deceleration rates, some discussion of the original studies in which they were determined is presented along with later literature on the continued applicability of these rates. While a large group of studies was performed around the same era, most of the design rates are based on *Speed-Change Rates of Passenger Vehicles*, of 1938 (7), with *Acceleration and Deceleration Characteristics of Private Passenger Vehicles*, of 1938 (11), and *Deceleration Distances for High-Speed Vehicles*, of 1940 (10), contributing to the deceleration-while-braking design rates.

Speed-Change Rates of Passenger Vehicles (7) was a study undertaken by D. W. Loutzenheiser of the U.S. Bureau of Public Roads to determine normal acceleration or “unhurried control” of a typical driver, full acceleration possible by typical drivers, and motor deceleration while in gear (no braking). Six passenger vehicles were used for this study, two 1935s (6-cylinder), one 1936 (8-cylinder), and three 1937s (one 8-cylinder and two 6-cylinder vehicles). Each vehicle was driven by multiple drivers during testing. No trucks or buses were included in this study. All vehicles were manual transmission, as the automatic transmission was rare in 1938.

Acceleration and deceleration rates were determined by taking stopwatch readings at 16 km/h increments. Normal acceleration values were determined based on a series of trials with various initial and final speeds, including 0 to 48, 0 to 64, 0 to 80, 0 to 96, 0 to 112, 32 to 64, 32 to 80, 32 to 96, and 32 to 112 km/h. Deceleration in gear trials included 96 to 32, 80 to 16, 64 to 16, 48 to 16, and 112 to 32 km/h. Figure 1.24 shows the calculated speed-time acceleration curves for normal and full acceleration, and Figure 1.25 shows the

calculated speed-time motor deceleration curves. Table 1.12 presents the actual speed-time information from the study. From this table the relevant 1965 AASHO guide deceleration and acceleration rate figures may be generated. For example, utilizing Table 1.12 to determine the distance traveled while accelerating from 32 to 72 km/h, a length of $31+42+53+69+85 = 280$ m is calculated. Utilizing Figure 1.24 based on the 1965 AASHO guide, the length is approximately this same value.

In Table 1.12, the rates are the average for each 5 mph interval and the distance is calculated based on the time elapsed and the average speed for each interval.

Table 1.12. Speed-change distances (Ref. 7)

Time, Rate, and Distance of Speed Change for 5 mph Increments
(basic data derived from trial runs on modern passenger vehicles)

Speed mph	Normal Acceleration			Full Acceleration			Deceleration in Gear		
	Time, Sec.	Rate, Mphps.	Distance, Feet	Time, Sec.	Rate, Mphps.	Distance, Feet	Time, Sec.	Rate, Mphps.	Distance, Feet
0-5	1.7	2.9	6	1.3	3.9	5	—	—	—
5-10	2.0	2.5	22	1.4	3.6	15	—	—	—
10-15	2.3	2.2	42	1.5	3.3	28	7.8	0.65	143
15-20	2.7	1.9	70	1.6	3.1	41	6.2	0.8	159
20-25	3.0	1.7	99	1.7	2.9	56	5.2	0.95	172
25-30	3.4	1.5	137	1.9	2.6	77	4.5	1.1	182
30-35	3.7	1.35	176	2.1	2.4	100	4.0	1.25	191
35-40	4.1	1.2	226	2.3	2.2	126	3.6	1.4	196
40-45	4.5	1.1	280	2.6	1.9	162	3.2	1.55	199
45-50	4.8	1.0	335	2.9	1.7	202	2.9	1.7	202
50-55	5.2	0.95	400	3.3	1.5	254	2.6	1.9	203
55-60	5.6	0.9	473	3.8	1.3	321	2.4	2.1	203
60-65	5.9	0.85	541	4.4	1.1	403	2.2	2.3	202
65-70	6.3	0.8	624	5.1	1.0	505	2.0	2.5	198

Source: Table 1, *Speed-Change Rates of Passenger Vehicles*, D.W. Loutzenheiser, Highway Research Board, 1938, p. 93

An assumption in this study is that full acceleration rates are mechanically controlled whereas normal acceleration is a function of driver characteristics. To determine normal acceleration rates the test drivers were instructed to drive “normally.” The study recognized that the test drivers were more aware of their acceleration during the study than would ordinarily be the case under typical freeway conditions, possibly causing the rates to differ slightly from actual “normal” acceleration rates. However, the rates were considered

acceptable for design because they agreed with results from other studies and appeared sufficiently below full-acceleration rates.

The study *Acceleration and Deceleration Characteristics of Private Passenger Vehicles*, of 1938 (11), is one of the sources utilized for determining (for passenger vehicles) the maximum “comfortable” deceleration rate while braking. In addition, this study looked at maximum acceleration rates and freewheeling deceleration rates. While these rates are not directly utilized in the 1965 AASHO guide, the guide does refer to this study as showing general agreement with the utilized rates.

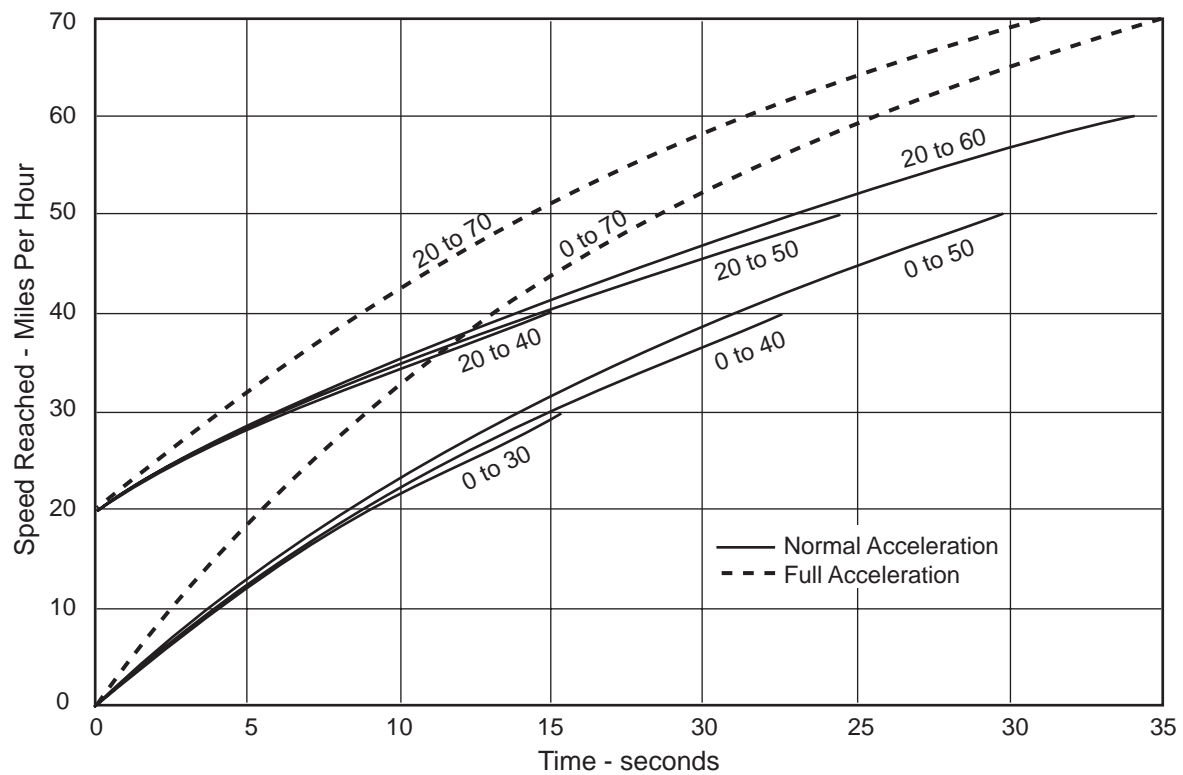

(Source: Figure 2, Ref. 11, p. 92)

Figure 1.24. AASHO 1965, speed-time acceleration

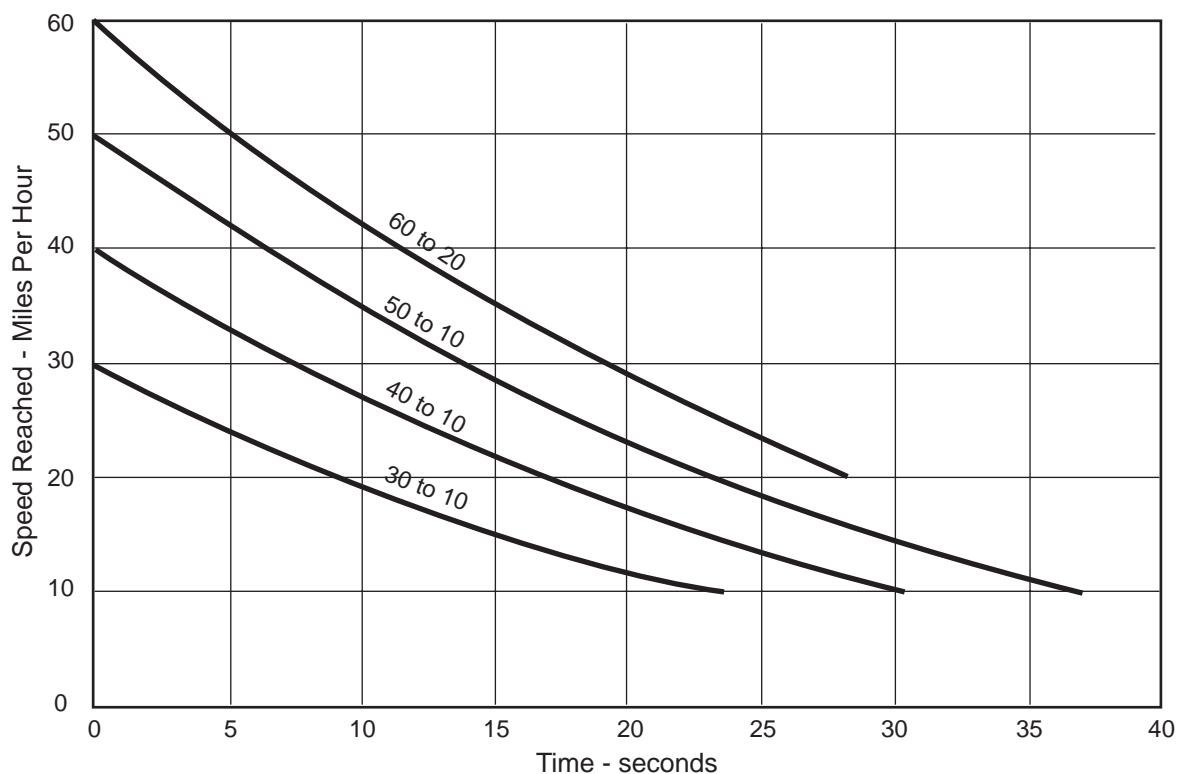

(Source: Figure 3, Ref. 11, p. 92)

Figure 1.25. AASHO 1965, speed-time deceleration

To determine a comfortable deceleration rate, a stop-controlled intersection was observed where vehicles were decelerating from rural highway speeds. The vehicles were considered to be operated under normal conditions and the drivers were unaware that they were under observation. To determine the deceleration rates, successive intervals of 15, 30, 45, 61, and 76 m were measured from the stop line. The time for a vehicle to travel through each interval was recorded, with observations rejected for vehicles not brought to a complete stop. Figure 1.26 shows the speed and deceleration curves for the vehicles approaching the stop sign. It was observed that vehicles that were traveling at higher speeds before decelerating tended to decelerate at higher rates throughout the stopping maneuver and to begin deceleration at a distance farther from the stop bar. (This observation is supported by a 1968 study where it was observed “that high speed vehicles had maximum values of both acceleration and deceleration with lower speed vehicles having less extreme values” [32].) Therefore, it was concluded in the 1938 study that only vehicles that began deceleration at higher speeds had a rate of deceleration that exceeded 12.9 km/h/s and that 14.4 km/h/s could probably be considered the maximum rate of deceleration that could occur without passenger discomfort.

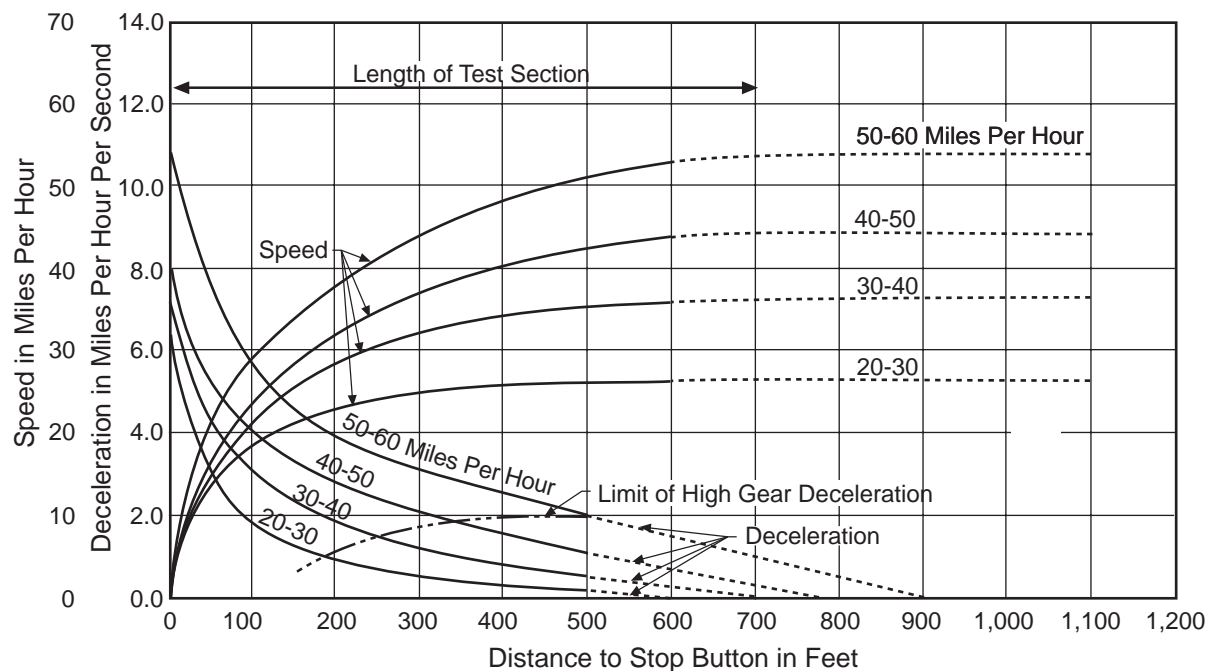

(Source: Figure 7, Ref. 11, p. 86)

Figure 1.26. Speed-distance relationships

A second study utilized by the 1965 AASHO manual is *Deceleration Distances or High-Speed Vehicles* (10). While the information used from this study concerns the determination of “comfortable” deceleration rates, the study also includes a determination of maximum deceleration, deceleration due only to engine braking (including air and rolling resistance), and deceleration due only to air and rolling resistance. The data calculated are stated to be representative of a number of vehicles of different makes and models, although the particular vehicles are not listed in the study, except for a mention that fifteen vehicles were from the 1940 model year.

Whereas drivers were unaware that they were observed in the previous study, this study was performed on the General Motors Proving Grounds and used eight different test drivers, all considered experienced. Speeds were observed and distance measurements made using a fifth-wheel speedometer and counter. The results of the determination of comfortable deceleration rates while braking from 112 km/h are shown in Table 1.13. The deceleration rates shown are averages, based on initial speeds and stopping distances. It was concluded that the average deceleration rate for comfort should not exceed $2.59.2.74$ m per sec².

While the sources for the acceleration and deceleration rates for design in the 1990 AASHTO guide and the 1988 TxDOT guide are studies from the late thirties and early forties, similar studies have been performed more recently. One source for more recent acceleration and deceleration rates is the *Transportation and Traffic Engineering Handbook* (14). Charts from this handbook and the 1938 study are presented to aid the reader in gaining some insight into the changing characteristics of vehicles and driver behaviors. Figure 1.27 represents the speed-distance relationships observed during maximum rate acceleration for passenger cars (circa 1970 vehicles) on level +6 percent and +10 percent grades and two-axle, single-unit trucks on level and +6 percent grades. Adjacent to this is Figure 1.28, taken from the *Speed-Change Rates of Passenger Vehicles*, a 1938 report showing the maximum acceleration rates for passenger vehicles on level roads. A comparison of acceleration rates shows maximum rates of the later-model vehicles to be substantially greater than those of the thirties' vehicles. For example, the distance to accelerate from 0 to 80 km/h decreases from slightly more than 244 m to slightly less than 152 m, approximately a 40 percent decrease, and the distance to accelerate from 0 to 112 km/h decreases from nearly 701 m to nearly 396 m, approximately a 45 percent decrease. The handbook also lists measured normal acceleration and deceleration rates, which are reproduced in Table 1.14.

Table 1.13. Comfortable deceleration rates from Ref. 10

Stops from 70 mph

Comfortable to passengers.....	}	619 ft = 8.55 ft per sec ² average
Preferred by driver.....		
Undesirable by not alarming to passengers.....	}	479 ft = 11.05 ft per sec ² average
Driver would rather not use.....		
Severe and uncomfortable to passengers. Slides packages and objects off seats.....	}	380 ft = 13.90 ft per sec ² average
Driver classes as an emergency stop.....		

Source: Table 1, *Deceleration Distances for High Speed Vehicles*, Ernest E. Wilson, Highway Research Record, 1940, p. 397

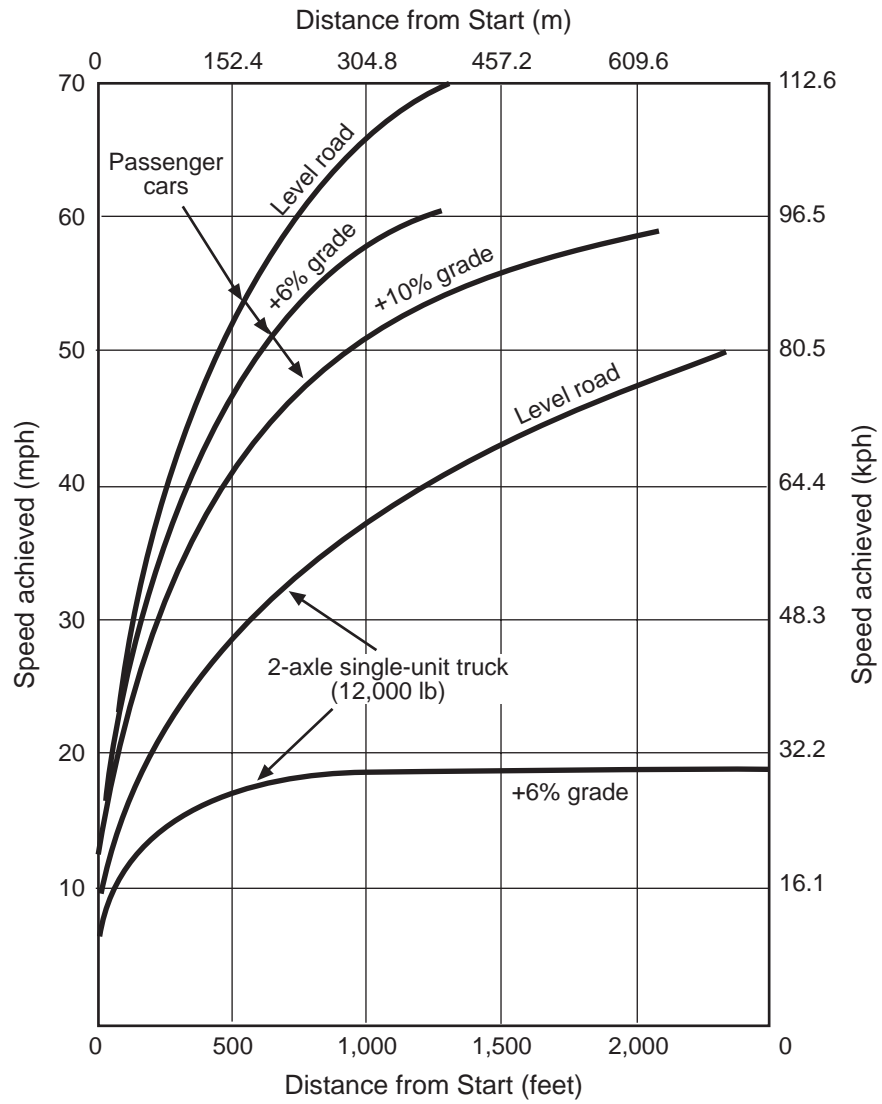

(Source: Figure 6.12, Ref. 14, p. 167)

Figure 1.27. Speed-distance relationships

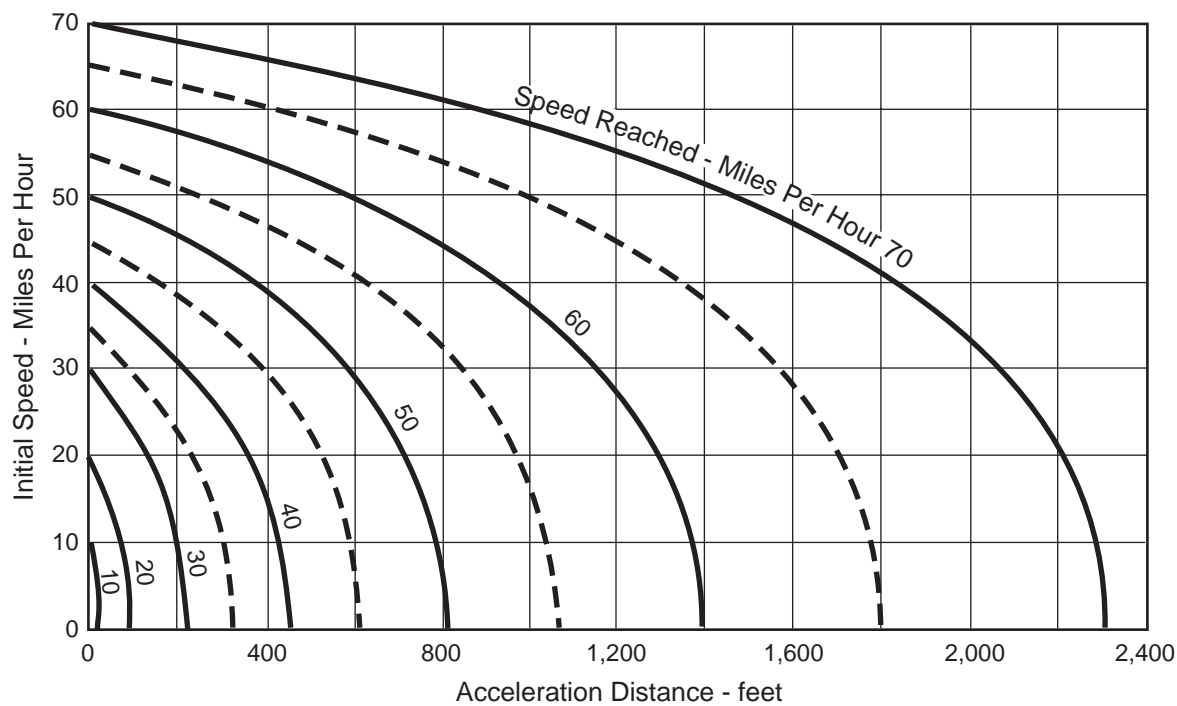

(Source: Figure 8, Ref. 11, p. 95)

Figure 1.28. Speed distance relationships

Table 1.14. Normal acceleration and deceleration rates from Ref. 14

Speed Change		Accelerations		Decelerations	
mph	km/h	mph's	km/h/s	mph's	km/h/s
0-15	0-24	3.3	5.3	5.3	8.5
0-30	0-48	3.3	5.3	4.6	7.3
30-40	48-64	3.3	5.3	3.3	5.3
40-50	64-80	2.6	4.2	3.3	5.3
50-60	80-97	2.0	3.2	3.3	5.3
60-70	97-113	1.3	2.1	3.3	5.3

Source: Table 6-47, Transportation and Traffic Engineering Handbook, 2nd edition, Institute of Transportation Engineers, p.169

These data were obtained using a test vehicle to match the speed-change rates of cars in traffic and to measure acceleration and deceleration rates. Acceleration rates are based on passenger cars starting up after a traffic signal turns green and on passing on a four-lane divided highway.

A comparison of these normal acceleration rates with those from the 1938 study (Table 1.12) leads to the conclusion that an increase in “comfortable” acceleration rates has occurred. For example, for the 8.16 km/h interval the normal rate increases from 4.0 to 5.3 km/h/s, an approximate increase of 32 percent. An even higher increase of approximately 140 percent is seen in the 64 to 80 km/h speed-change interval (from 1.8 to 4.2 km/h/s). The normal acceleration rates for the more recent data in the 64 to 80 and 80 to 96 km/h speed-change intervals exceed even the full-acceleration rates of the 1938 data. It has been suggested that part of the reason for the substantial difference in normal acceleration rates between the two studies is the difficulty in defining “normal” acceleration (13). Clearly the AASHTO design values are more conservative than those of the *Transportation and Traffic Engineering Handbook*. Olson (13), who references further investigations of ramps and speed-change lanes (19), found that the handbook values were more representative than those in the 1938 study.

Acceleration rate characteristics were further studied in *Acceleration Characteristics of Late-Model Automobiles* (17). This study examined model year vehicles in 1971, 1973, 1975, 1977, and 1979 by gathering passenger car acceleration rate data from *Consumer Reports*, *Motor Trend*, and *Car and Driver* magazines. While it was seen that vehicles actually had decreasing maximum acceleration rate capacities between 1971 and 1979, in all cases the maximum rates exceeded those of the late thirties’ vehicles used by AASHTO. It was evident in this study that a 1979 vehicle was able to accelerate to a speed in a much shorter distance than those vehicles used in the 1930 studies.

Some of the loss in acceleration rate over the seventies may be attributed to federal mandates for fuel-efficient cars (a response to the energy crisis in the early seventies [17]). While no similar studies for eighties’ and nineties’ vehicles have been found, the trend in automobile purchases has clearly gone away from the light-car trend of the seventies. As sport utility vehicles and pickup trucks become best-selling vehicles, it would clearly be a valid assumption that the maximum acceleration characteristics of the average vehicle today still greatly exceed those of the thirties’ vehicles. This assumption is supported by Stuard (18), whose observations at an intersection showed that late-model vehicles (1983–1986) had the highest average acceleration rates and that older vehicles had lower average acceleration rates.

Olson (13) presents some discussion on basing speed-change lane lengths on the higher, updated average acceleration values; at the same time he realizes that these higher rates would substantially reduce the current AASHTO-recommended speed-change lane lengths. A belief is expressed that “such drastic changes should be examined critically.” The methodology used in the 1965 AASHO manual did not model the gap acceptance process;

Olson recognizes that the longer lengths, as determined by the more conservative 1938 rates, may be warranted for entering vehicles seeking a gap.

Clearly, there exists some uncertainty about the actual acceleration rates that would be best suited for design. It would appear that even though the rates from the thirties may be lower than those used by drivers today, the deficiencies in the AASHTO speed-change lane model (i.e., gap acceptance) may require these conservative rates to assure adequate lengths; that is, by updating acceleration and deceleration rates and utilizing the current AASHTO methodology, unrealistically low speed-change lane lengths most likely would result. While it is possible that the AASHTO lengths and design standards used are acceptable for TxDOT use, any study of ramp operations to determine if adequate designs are being implemented would certainly be justified. There are at least three possible outcomes when reviewing the speed-change lane design: 1) the designs are too conservative (the 1938 acceleration/deceleration rates are too conservative) and shorter lengths may be justifiable, 2) the designs are acceptable (the 1938 rates properly compensate for model deficiencies), and 3) the designs are inadequate (the 1938 rates do not adequately compensate for model deficiencies).

ACCIDENTS

One aspect of ramp design — and design in general — that has been sporadically studied over the past decades is the effect of geometric features on accident rates. One of the most thorough and frequently referenced reports on the relationship between accidents and design is *Analysis and Modeling of Relationships between Accidents and the Geometric and Traffic Characteristics of the Interstate System* (26). This study, based on data from twenty states, considered such items as number of lanes, design speed, lane width, maximum curvature, pavement type, grade, stopping sight distance, number of information and advertising signs, lighting, volume, and percent of commercial vehicles. The study presented several findings of interest, among them 1) that increased traffic volumes resulted in an increased number of accidents, 2) that traffic-oriented variables (i.e., volume, percent of trucks) contributed most to the variance in accidents on the interstate system, 3) that geometrics alone accounted for only a small portion of the variance in accidents, and 4) that no relationship could be determined between the geometrics studied and fatalities.

The third and fourth points involving geometrics are clarified within the report. The intent in presenting these points is not to show that geometrics do not impact accident rates, for surely poor geometrics will affect accidents; instead, these points are meant to suggest that current (pre-1970 at the time of the study) design standards were generally at a point where improvements or variations in geometrics would have little impact on accidents. The sites chosen for study by each contributing state were supposedly “representative” locations rather than high-accident locations. This selection process probably eliminated from study those interchanges and ramps where underdesigned geometric features would cause excessive accidents. Based on these constraints it was seen that traffic variables and geometrics accounted for 53 percent to 83 percent of the variance in accidents, with the remaining

assumed to be accounted for by other factors (i.e., weather, driver, vehicle). Additionally, when only interchange geometrics were considered, 0 percent to 20 percent of the accident variance was accounted for in most cases.

In considering the effects of geometrics, the study reported some interesting findings. Of the three full interchange types studied, the full cloverleaf appeared to be the most dangerous, though the full diamond and full slip ramp diamond had similar accident rates. Curiously, for low mainline volumes (fewer than 9,200 vehicles per day) the full diamond appeared safer than the partial cloverleaf, though as volume increased this relationship reversed. Also, the half diamond was the safest of all types of interchanges studied. Individually, a number of items appeared to have mixed effects on accident rates, with actual effects depending on the particular situation (i.e., interchange type, ramp type, number of lanes). These items included design speed, curvature, gradient, difference between exit and entrance ramps, lighting, and pavement markings.

As mentioned, states supposedly submitted “representative” data for analysis in this study. However, a small fraction of the data submitted did seem to have exceptionally high accident frequencies. For these interchanges a separate failure analysis was performed. This analysis better highlighted the effects of unusual design features, geometrics, and traffic characteristics not seen in the “representative” samples. Figure 1.29 shows the results based on the analysis of ramps having unusually high accident frequencies. While it is seen that accidents are still most frequently caused by the effects of high traffic volumes, additional information relating to geometrics indicates 1) that design speeds that are too low can increase accident frequency, and 2) that on most of the ramp types, poor geometric features (short speed-change lane, sharp curvature, and too short stopping sight distance) can also increase accident frequency.

More recently, additional accident experience results were published in *Accidents and Safety Associated with Interchanges*, of 1993 (21). While no original data collection or analysis was performed for this study, it did provide a review of data and experience from other research efforts. Some of the conclusions of this study were:

- Right-side and outer-connection ramps showed an increase in accidents rates with increasing maximum curvature (except in rural areas) (33).
- Outer-ramps in urban areas tend to show increasing accident rates with increasing average daily traffic (33).
- Straight outer-connection ramps typically have lower accident rates than curved outer connections (33).
- Off-ramps have considerably higher accident rates than on-ramps (34).
- Ramps in general were found to have the same accident rates regardless of upgrade or downgrade, with horizontal curvature being a more significant factor in accident rates (34).

- Left-side and scissor ramps have the highest accident rates, with diamond ramps having the lowest rates (34).
- Truck loss-of-control accidents are typically of the rollover or jackknife types (35).
- Truck rollover accidents typically occur on ramps when the truck speed exceeds design speeds (34).
- Both rollover and skidding potential must be checked when designing ramp horizontal curves to accommodate trucks (35).
- Where a sharp curve must be negotiated at the bottom of a ramp grade, it may be ill advised to follow the AASHTO policy that permits ramp downgrades of up to 8 percent (35).
- Collector-distributor roads should be considered in high-volume interchanges.
- The relative safety of an urban interchange is enhanced where 244 m or longer acceleration or auxiliary lanes are provided (36).
- Accident rates are reduced where deceleration lanes of 274 m or longer are utilized (36).

The above points are taken primarily from Twomey (21); but as this paper is a synopsis of other efforts, original sources are referenced (in parentheses) for most statements.

Accident analysis is often difficult to perform, given the inherent problems in data collection. Accident records are often incomplete, inaccurate, or too vague to allow for meaningful analysis. For example, to acquire the quantity of information needed for the *Analysis and Modeling of Relationships between Accidents and the Geometric and Traffic Characteristics of the Interstate System* study (26), accident data were gathered by 1) documents of accidents observed, 2) insurance company records, and 3) roving observers deployed on a 24-hour basis in conjunction with other traffic studies. In other studies, police records and/or accident data accumulated by various departments of transportation were used.

Variable [1]	Ramps of Diamond	Slip Ramps	Outer Connections	Direct or Semi-direct Connections	Loops
1. High Traffic Volumes, mainline	●	●	●	◐	●
2. High Traffic Volumes, ramps	●	●	●	◑	●
3. Unit Length – unusually long	○	○	◑	○	○
– unusually short	○	○	◑	○	○
4. Length of Adjoining speed change lane – Too short	◐	◐	◐	○	○
5. Type of Area – Urbanized	●	●	●	○	●
6. Intensity of Lighting – Too low	◑	◐	◑	◐	◑
7. Design Speed, Too low	◑	◐	◑	◑	○
8. Max. Grade, Too steep	○	◑	◑	◑	◐
9. Max. Curvature, Too sharp	◑	◐	◐	◑	○
10. Min. stopping sight distance, Too low	◐	◑	◐	◑	◑
11. Distance from nose to point of high curvature – Too short	◑	○	◐	◑	◑
12. Structure and guard rail clearance, Too small	◑	○	○	◐	◐
13. Delineators – Absence of	◑	◑	◑	◑	○
14. Type of crossroad (or frontage road for slip ramps)	◑	◑	○	—	◑
15. Traveling speed at time of accident, Too high	○	◑	○	◐	○
16. Percent commercial traffic, Too high	◑	◑	◑	◑	◑
17. Percent Out-of-state traffic, Too high	—	◑	—	◑	◑
18. Right and left shoulder type, presence of barrier curbs	◑	○	○	○	◑
19. Edge Markings – Absence of	○	○	○	◑	○

- Judged to have serious causative effect on accidents.
- ◐ Judged to have considerable causative effect on accidents.
- ◑ Judged to have some causative effect on accidents.
- Judged to have slight causative effect on accidents.
- Judged to have no causative effect on accidents.

[1] See Appendix V for specific values of each variable.

(Source: Based on Figure 18, Ref. 26, p. 23)

Figure 1.29. Accident experience versus causative factors

Other points have been raised in another study (22) in which the general conclusion was that current AASHTO design standards (specifically open-road horizontal curve design parameters) provide safe operation for both passenger cars and trucks. However, accidents (rollover and skidding) were observed to occur at undesirable levels when unrealistic design speeds were used. Where AASHTO design assumptions (i.e., speed of vehicle) are not violated, adequate margins of safety are provided; but where vehicles exceed design speeds, unsafe conditions — conditions that heighten the potential for accidents — may result. This conclusion (22) underscores the need for careful consideration of design speed and certainly leads one to at least question whether the AASHTO allowance of minimum ramp design speeds at 50 percent of the freeway design speed is reasonable.

The studies performed have had some conflicting findings. While one study found no actual relationship between geometrics and accidents, others found that improved geometric standards could reduce accidents. In any case, insightful results and conclusions were obtained despite the difficulties involved in data collection and analysis. Some correlation between some of the accident results and results obtained by attempts at modeling the ramp and speed-change lanes will be seen in the next section.

RESULTS FROM OTHER MODELS

The methodology used in the development of the AASHTO model of the speed-change lane length has been discussed in detail. Other researchers and agencies have attempted to refine the AASHTO approach or to develop new methodologies for the modeling of the ramp to/from freeway maneuver. The details of these models, along with some of their strengths and weaknesses, are presented in greater detail in a subsequent section of this report. This section discusses some of the results and conclusions of those studies pertaining to the AASHTO approach and to other models.

A model of freeway merging was developed based on driver behavior in *Driver Behavior Model of Merging*, by Michaels and Fazio (28). In general, the model divided the merging process into initial ramp curve tracking and transition to the speed-change lane, a repetitive process of acceleration and gap search, and a final steering to the freeway lane or aborting the merge. This model was tested against data obtained from 102 merges, which included both curved and tangent connectors to the speed-change lane. A major deviation of this model from the AASHTO methodology is the concept of an iterative process between acceleration and gap search; that is, the two events do not occur simultaneously and are performed in a repetitive process, one after the other. It was determined that after one acceleration/gap search trial, 20 percent of the vehicles had merged; after two trials, 62 percent had merged; and after three trials, 98 percent had merged. Based on the modeling of this behavior and on the other aspects of the model, speed-change lane lengths were developed for ramp design speed vs. freeway lane volumes. Figure 1.30 shows the length of speed-change lanes for various ramp design speeds required for the 85th percentile gap acceptance.

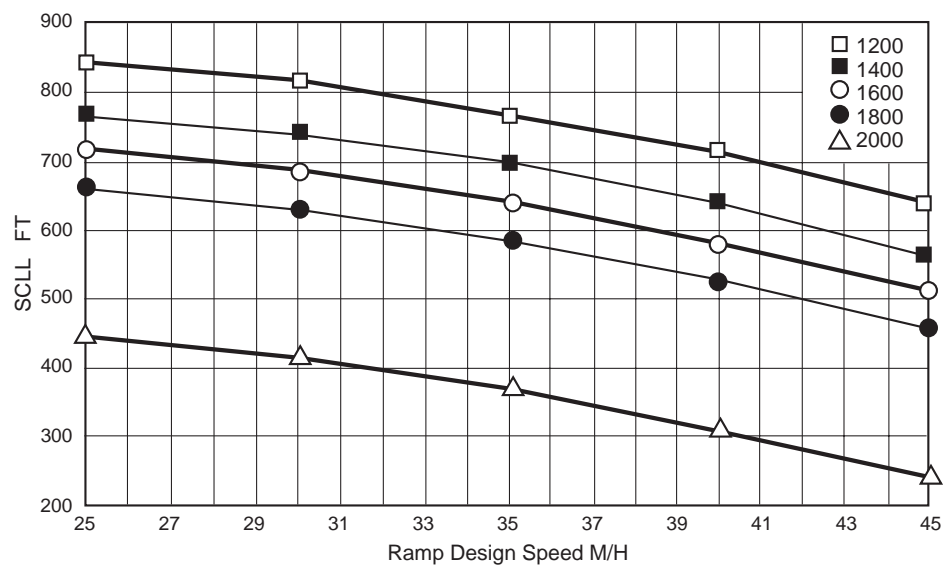

(Source: Figure 6, Ref. 28, p. 9)

Figure 1.30. Speed-change lane lengths by ramp design speed for 85th percentile gap acceptance

There are several notable conclusions that may be drawn from this study. The first involves the rate at which the recommended length of the speed-change lane decreases as the ramp design speed increases. For example, at a freeway volume of 1,200 pcplph (passenger cars per lane per hour) a 50 percent increase in ramp design speed (from 48 to 72 km/h) results in a 20 percent decrease in recommended speed-change lane length. While the AASHTO methodology also leads to decreasing speed-change lane lengths as ramp design speed increases, the rate of increase is substantially higher. For the same example, but utilizing the AASHTO methodology, on a freeway with a 112 km/h design speed, there is a nearly 40 percent reduction in speed-change lane length recommended. The irony of this study is that it leads the reader to the conclusion that the AASHTO guide may provide better operation at low ramp design speed than it does at high ramp design speeds. For example, based strictly on a comparison of the values from these two studies, for a 96 km/h freeway the AASHTO guide, when compared with Michaels and Fazio, would provide the same or longer lengths for ramp design speeds of 48 and 56 km/h and shorter lengths for ramp design speeds of 64 and 72 km/h. Although caution must be exercised in directly comparing this study with AASHTO owing to the limited sample size and potential differences in measuring speed change length, the trend toward reducing the speed-change lane length at a rate less than that utilized by AASHTO is clear. This conclusion is supported by the accident analysis in the previous section, where recommended minimum speed-change lane lengths are higher than those recommended by AASHTO for the higher ramp design speeds.

A second point of interest in this study is that the required length of a speed-change lane decreases as the ramp volume increases. The reason for this was an assumption that the freeway speed declined as the volume increased. (Mean freeway speeds for this analysis were based on the *Highway Capacity Manual* [37].) The importance of this point is that when studying the operation of speed-change lanes, the critical operation for determining the acceptability of the design may actually occur during off-peak, lower-volume periods.

A more detailed study with which the above study was connected is the unpublished NCHRP 3.35 *Speed-Change Lanes, Final Report*, of 1989 (9). This study was wide ranging, evaluating current design guidelines for speed-change lanes, developing a model of speed-change lane operation, and developing new guidelines for speed-change lane design. Like the model in the previous study, this model attempted to better capture the influence of traffic flow characteristics and driver behavior. The models developed attempted to integrate the human factor dimension with geometry and vehicle operational characteristics. In addition to AASHTO requirements for speed-change lane design, this study also considered minimizing the disruption to freeway flow, meeting driver expectations, and avoiding overlapping control requirements for the driver. For example, this study defines ideal entrance ramp design as “one which minimizes the likelihood of overload and is adapted to the behavioral requirements of the entry process.” Furthermore, the design objective should be to “provide a static and dynamic environment that has maximum predictability for the driver.” For this study, design was based on the 85th driver percentile, meaning that 85 percent of the drivers should be able to complete the required maneuver (i.e., entry maneuver) in a shorter length than recommended.

There are some differences between the assumptions of this study and those of the AASHTO study: For example, the AASHTO model bases speed-change lengths on operating speeds, which are lower than the design speeds, whereas NCHRP 3.35 assumes operating speeds equal design speeds. In addition, the AASHTO 1990 guide defines the speed-change lane to begin or end at the 3.7 m taper; NCHRP 3.35 uses the 1.8 m point. Also, the NCHRP model utilizes several speeds along the length of the ramp and does not utilize the 8 km/h differential speed between the ramp vehicle and freeway operation as a merging threshold, instead utilizing an angular velocity threshold. These differences highlight the changing approach toward modeling speed-change lanes.

When compared to the AASHTO speed-change lane length design values, the models developed in this study produced slightly shorter lengths at high freeway speeds and significantly longer at moderate-to-low freeway speeds for acceleration lane lengths, and significantly longer deceleration lane lengths for all freeway and ramp speeds. Table 1.15 provides a typical comparison of recommended acceleration lane lengths by AASHTO and NCHRP 3-35. In this table the AASHTO values have been adjusted to be comparable to NCHRP 3-35 lengths; a detailed explanation of adjustments is given in the NCHRP report. This table suggests AASHTO may be too quickly reducing the speed-change lane lengths as

speed differentials decrease, i.e., the AASHTO 80 km/h freeway/64 km/h ramp combination seems insufficient while the AASHTO 112 km/h freeway/64 km/h ramp combination seems more than sufficient when compared with NCHRP 3.35.

As mentioned, the deceleration lane lengths determined in this study were generally higher than those recommended in AASHTO. Table 1.16 compares NCHRP 3.35 recommended deceleration lengths with those of AASHTO. The NCHRP 3.35 speed-change lane lengths (L_{SC}) are seen to vary from 95 percent to 144 percent of the lengths recommended by AASHTO. This study also observed on existing exit ramps the phenomenon of vehicles beginning to slow down before entering the speed-change lane, with this being especially predominant on shorter exit ramps.

Table 1.15. Comparison of NCHRP 3.35 and AASHTO values for acceleration lane length (from Ref. 9)

V_r' (mph)	Acceleration Lane Length (ft)					
	70		60		50	
	3-35	AASHTO	3-35	AASHTO	3-35	AASHTO
0	---	---	---	---	---	---
15	---	---	---	---	---	---
30	2,162	2,795	1,933	2,070	1,431	1,345
40	2,107	2,795	1,669	2,070	1,628	1,345
50	1,899	2,795	1,941	2,070	---	---
60	2,230	2,795	---	---	---	---

$V_0^1 = 30$ mph
 Lane 1 Volume = 1,800 peph
 Ramp Volume = 200 peph

SUMMARY

These studies have clearly raised doubts about the applicability of AASHTO design and, accordingly, TxDOT design standards based on AASHTO. There is the possibility that AASHTO's acceptance of a minimum ramp design speed of 50 percent of the freeway design speed is inadequate; moreover, at high speeds the recommended AASHTO lengths may be too short. When considering the potential problem for TxDOT entrance ramp design standards, some of the higher ramp speed design concerns are alleviated because TxDOT utilizes a single design that provides lengths greater than the AASHTO-recommended lengths for higher ramp design speeds. However, the TxDOT design has been shown to be possibly shorter than that recommended in the 1990 guide for low ramp design speeds. When considering deceleration, TxDOT's standard design faces the same issues as does AASHTO's design, because the lengths it uses are simply a rounded version of the AASHTO lengths.

In discussing the AASHTO acceleration and deceleration rates several possibilities were mentioned as to their applicability in today's design. One possibility was that the 1938 acceleration and deceleration rates might not adequately compensate for deficiencies in the AASHTO model. These studies would lead to the conclusion that this is the likely situation.

Table 1.16. Exit model component analyses (from Ref. 9)

$V_d' = 70$ mph										
V_c' (mph)	L_{DS} (ft)	L_{SC} (ft)	t_g (f/s/s)	L_{DG} (ft)	V_g' (mph)	L_{DB} (ft)	D_b (f/s/s)	L_{SCL} (ft)	AASHTO Length (ft)	L_{SCL} as % of AASHTO (%)
0	578	154	6.5	605	45.7	354	9.8	1,113	915	122
15	578	154	5.5	521	58.8	360	9.7	1,035	905	114
20	578	154	4.5	433	60.8	366	9.7	953	895	106
25	578	154	3.5	342	62.9	372	9.7	868	875	99
30	578	154	3	295	63.9	375	9.2	825	845	98
40	578	154	3	295	63.9	375	7.1	825	745	111
45	578	154	3	295	63.9	375	5.9	825	705	117
50	578	154	3	295	63.9	375	4.6	825	605	---
$V_d' = 60$ mph										
V_c' (mph)	L_{DS} (ft)	L_{SC} (ft)	t_g (f/s/s)	L_{DG} (ft)	V_g' (mph)	L_{DB} (ft)	D_b (f/s/s)	L_{SCL} (ft)	AASHTO Length (ft)	L_{SCL} as % of AASHTO (%)
0	509	132	3	251	53.9	345	9.1	728	765	95
15	509	132	3	251	53.9	345	8.4	728	735	99
20	509	132	3	251	53.9	345	7.8	728	725	100
25	509	132	3	251	53.9	345	7.1	728	695	105
30	509	132	3	251	53.9	345	6.3	728	675	108
35	509	132	3	251	53.9	345	5.3	728	625	116
40	509	132	3	251	53.9	345	4.1	728	565	129
45	509	132	3	251	53.9	345	2.8	728	505	144
50	509	132	5	404	49.8	---	---	536	425	---
$V_d' = 50$ mph										
V_c' (mph)	L_{DS} (ft)	L_{SC} (ft)	t_g (f/s/s)	L_{DG} (ft)	V_g' (mph)	L_{DB} (ft)	D_b (f/s/s)	L_{SCL} (ft)	AASHTO Length (ft)	L_{SCL} as % of AASHTO (%)
0	433	110	3	207	43.9	311	6.7	628	625	100
15	433	110	3	207	43.9	311	5.9	628	600	105
20	433	110	3	207	43.9	311	5.3	628	575	109
25	433	110	3	207	43.9	311	4.5	628	545	115
30	433	110	3	207	43.9	311	3.6	628	505	124
35	433	110	8	492	33.7	---	---	602	455	132
40	433	110	5	330	39.8	---	---	440	395	111
45	433	110	4	270	41.8	---	---	433	325	133
50	433	110	3	207	43.9	---	---	433	---	---

(Source: Based on Table 15, Ref. 9, p. 136)

CHAPTER 2. SURVEY OF DESIGN PRACTICE

In addition to examining the history and implications of ramp design speed criteria, current practice was also studied. During the literature review, we determined that the National Cooperative Highway Research Program's (NCHRP's) Study 3-35, *Speed-Change Lanes Final Report*, was potentially useful. Part of that study included a survey of sixty agencies, including all fifty state transportation agencies, regarding speed-change lane design practices. Although the survey data were not published, we located one of the original contractors, who graciously provided a working paper describing survey results. Even though the survey does not explicitly address ramp design speed, the core ramp design speed issue is really speed change, which the survey does deal with directly. The list of survey respondents is provided as Table 2.1 and a quantitative summary of results is provided as Table 2.2. The speed-change lane survey was summarized, in part, as follows:

Forty-three surveys were returned and reviewed. . . . A majority of the agencies contacted use AASHTO as the basis for speed-change lane design. However, a significant number of agencies incorporate standards other than AASHTO's for certain design elements, such as minimum lengths of acceleration and deceleration lanes, and taper rates. The greatest design difference lies in minimum acceleration lane length, where standards range from 900 feet to 1200 feet, less than the AASHTO recommended 1350 feet minimum. Several agencies use complex tables to determine appropriate taper rates and acceleration lane lengths. Nearly all agencies which responded either exceed or comply with AASHTO recommendations for deceleration lane lengths. The survey results also showed that the majority (67 percent) of responding design agencies use both parallel and taper type design depending on the location and freeway conditions. The remaining agencies use either taper or parallel type design exclusively, with taper being predominantly favored. The results of this survey agreed with Baker's (1) review of ten state design manuals. Interestingly, several respondents to this survey continue to base their design guidelines on AASHTO's Blue and Red Books rather than the more recent Green Book.

The second section of the survey pertained to what measures designers use to evaluate the operational effectiveness of speed-change lanes. Greatest importance was placed on the speed difference between through traffic and merging/diverging vehicles. Acceleration/deceleration rates and the average (or critical) gap accepted at merge were also considered reasonable measures of operational effectiveness. The point of entry/exit along the merge/diverge area, the freeway speed through the merge/diverge area, and the number of brakings through the merge/diverge area were not considered to be effective

measures of operation. Several respondents mentioned other measures of operation such as ramp and freeway traffic volumes, accident rates, and driver understanding.

Table 2.1. NCHRP 3-35 survey respondents, from Ref. 9

STATE DESIGN AGENCIES

Alabama	Montana
Alaska	New Hampshire
California	New Jersey
Colorado	New Mexico
Connecticut	New York
Florida	North Dakota
Hawaii	Ohio
Idaho	Oklahoma
Illinois	Oregon
Indiana	Pennsylvania
Iowa	Rhode Island
Kansas	South Dakota
Kentucky	Texas
Louisiana	Utah
Maryland	Vermont
Massachusetts	Virginia
Michigan	Washington
Minnesota	Wisconsin
Mississippi	Wyoming
Missouri	

OTHER DESIGN AGENCIES

Federal Highway Administration, TAMS, HDR Engineering, Jack E. Leisch & Associates

Table 2.2 Summary of speed-change lane survey response, from Ref. 9

(Total Responses - 45)

DESIGN

AASHTO Compliance	Design Differences (As a Percentage of Total Respondents)						Preferred Ramp Types		
	Length	Width	Taper Rate	Design Vehicle	Acc./Dec. Rate	Other	Parallel	Taper	Parallel & Taper
89%	20%	2%	16%	2%	2%	7%	9%	24%	67%

MEASURES OF OPERATION

	Speed Difference	Entry Point	Freeway Speed	Number of Brakings	Accel./Decel. Rate	Average Gap	Other
Mean Rank	1.8	4.5	4.2	4.3	2.8	3.5	5.3
Standard Deviation	1.0	1.8	1.4	1.5	1.3	1.5	2.7

Based on the response from the survey of design and operational experience, ten design agencies were selected for a more in-depth, follow-up interview. The selection criteria were designed so as to include a comprehensive representation of speed-change lane design guidelines, both qualitatively and geographically. The design agencies selected for follow-up interviews included the transportation departments of the states of New Mexico, Massachusetts, Oregon, Louisiana, California, Ohio, Maryland, New Hampshire, Missouri, and Mississippi. The purpose of the interviews was to gather specific information on design criteria which experienced designers currently include or feel should be included in the design process.

Review of the interview results clearly showed that current design practices for speed-change lanes vary between states. AASHTO guidelines are usually used as a basis from which each state design agency incorporates its own unique design criteria. Most states conform with AASHTO requirements for minimum speed-change lane length and adjust the length depending on local conditions, such as gradient, ramp type and curvature, speed differential, and truck percentages. AASHTO mentions the effect of high percentages of heavy vehicles on speed-change lane length, although does not provide any quantitative adjustment criteria. Maryland, Ohio, and California have prepared their own unique design guidelines. Most of the design criteria have resulted from experience, with the exception of California which performed in-house research over an extended period (HRB Bulletin 235, 1960). The Ohio DOT defines speed-change lane length as a function of

three different classes of facilities. The purpose of the class system is to separate rural, urban, and limited access control highway design. All of the states interviewed use both parallel and taper designs, sometimes in combination. Several states noted that in following AASHTO's guidelines for a tapered acceleration lane design, there is some confusion as to whether the entire taper length should be included in the acceleration lane length. Although both ramp types are used, the perception of driver behavior on a parallel versus tapered design differed. Ohio and Maryland feel a parallel element in an acceleration lane offers the motorist the opportunity to scan freeway traffic for an acceptable gap. Conversely, several other states feel that parallel acceleration lanes do not operate well and provide the perception to the driver of an auxiliary lane. These latter states feel that a tapered design gives the driver a better view of the freeway and adds to the natural merging process. All of the states interviewed prefer tapered deceleration lanes.

None of the states interviewed have experienced any significant operational problems related to either AASHTO or in-house design criteria. Review of accident records is the primary, if not exclusive, measure of speed-change lane performance. Actual field observation, data collection, and analysis is limited. In an effort to identify critical design factors, comments on suggested factors were requested from each designer. As expected, the comments varied, however, a partial consensus was reached. In general, the designers interviewed felt that gradient, volume, speed, truck percentage, and angle of merge are important, if not critical design factors which should be included in speed-change lane design guidelines. Although most of the designers agreed that angle of merge is an important design factor, several noted that it was only a factor on the older designs, but continued consideration should be given in order to maintain small merge angles on new designs. Lane-width was viewed as a constant, while driver type was not considered an important design factor. Several of the designers, especially those familiar with urban freeway design, suggested that a method of delineating urban versus rural design, possibly similar to Ohio's classification system, should be included in design guidelines. Consideration of horizontal and vertical sight distances is necessary, but is usually accounted for in the design. Most of the design agencies interviewed use a single design vehicle, although several designers noted that the percentage and type of truck traffic can have a strong impact on the design. This suggests that an improved design vehicle incorporating truck characteristics, or a quantitative method of adjusting acceleration/deceleration lane length due to heavy truck traffic, may be appropriate. Input on the candidate research sites obtained from the earlier survey was also received during the interviews.

Results of Design Experience Review

Both the design experience questionnaire and the in-depth interviews provided insight into the practical applications of current AASHTO design criteria. From the designer's viewpoint, several deficient areas of AASHTO guidelines were identified. Initially, the Research Team attempted to define specific measures of effectiveness which might be used by designers to evaluate speed-change lane performance. Although several reasonable MOEs were identified in the design experience questionnaire, further discussion during the in-depth interviews showed that nearly all design agencies use only accident data for speed-change lane evaluation. Little or no field observations are performed. Therefore, it seems unreasonable to assume that design agencies will evaluate speed-change lane operation based on field observed critical gaps, speed difference, or acceleration/deceleration rates.

Designers did express the need for clarification of several AASHTO design elements. One such element is to provide a quantitative method of incorporating high percentages of heavy vehicles into the design process. Similarly, design differences within rural and urban areas need to be addressed. Further evaluation of driver behavior on speed-change lanes, especially as it relates to rural versus urban areas, is necessary. Finally, although little mention was made of the importance of traffic control devices on speed-change lanes, further research, especially as it relates to driver behavior, appears to be warranted. In particular, ramp metering within urban areas may have a significant impact on the operation of acceleration lanes. Similar to the results of the literature review, few designers mentioned any problems with deceleration lanes. Therefore, it may be appropriate to direct more of the research effort towards acceleration lane operation and design, especially during the data collection effort.

Significant findings developed through the survey included, among others, 1) acceleration operations are viewed as more problematic than deceleration, 2) driver behavior during speed changes is not well characterized, 3) virtually all agencies rely upon accident experience as the primary performance evaluation measure, 4) very little operational data describing speed change or ramp operations are collected, and 5) all agencies do not use the same design criteria. Additionally, effects of control devices, specifically ramp metering, are not well known.

Although this survey was conducted almost 10 years ago, major changes in these findings are not very likely. The literature review confirmed that little operational data have been collected either by agency activities or research efforts. The research team, therefore, recommends that those efforts that would be expended on a current follow-up survey be expended on other, more productive work tasks. However, some valuable information would

be almost certainly produced by a survey designed specifically to deal with the issues of this study. Therefore, a new survey instrument has been designed and is provided as Figure 2.1. If the TxDOT project director and advisory panel recommend collection of additional national practice data, the research team is prepared to finalize and distribute this instrument.

SUMMARY

Design practice was examined through the extensive first chapter literature review, which led to discovery of a speed-change lane nationwide survey. Results of the survey tend to confirm intuitive concepts rather than suggest changes in study direction. Although a new survey instrument has been developed, conducting a new survey does not seem imperative, and resources that would be expended on that effort could be very productively used in the data collection effort suggested in Chapter 3.

Survey Questionnaire

Questions A1) to A4) are general questions regarding what source(s) your agency utilizes for ramp design guidelines.

A1) For ramp design, including the ramp terminal at the freeway and the ramp proper, does your agency utilize the AASHTO design guide, an agency design guide, or both? (Circle one)

AASHTO guide only Agency guide only Both

A2) If in question A1) you answered “both,” which manual is considered to provide minimum acceptable design values? (Circle one)

AASHTO guide Agency guide

A3) If in question A2) you responded that your agency utilizes an agency design manual to provide minimum design values, are any of these values (in regard to ramp design) less than those recommended in AASHTO? (Circle one)

Yes No

A4) Is your agency currently designing new projects according to metric or English design guidelines? (Circle one)

Metric English

Questions B1) to B4) relate to AASHTO Table X-1, which is attached to this survey. This table provides guidelines for upper, middle, and lower range ramp design speed, in relation to the highway design speed.

B1) Does your agency utilize Table X-1 as shown? (Circle one)

Yes No

B2) If you answered “No” to question B1), please markup Table X-1 attached to this survey or attach to this survey a copy of your agency’s guidelines regarding ramp design speed.

B3) If you answered “Yes” to question B1), does your agency provide any additional sidelines beyond what may be found in the AASHTO guide in regards to what conditions upper, middle, or lower range design values should or must be used? (Circle one)

Yes No

B4) If you answered “Yes” to question B3), please attach a brief summary of your agency’s guide or a copy of the appropriate pages from your design guide.

Figure 2.1. New survey questionnaire

Questions C1) to C5) relate to the design of ramp terminals, specifically speed-change lanes on highways.

- C1) In designing ramp terminals, specifically for a single-lane entrance/exit ramp, does your agency utilize parallel type design only, taper type design only, or both?

Entrance ramps (Circle one)

parallel only taper only both

Exit ramps (Circle one)

parallel only taper only both

- C2) If you answered “both” for either exit or entrance ramps, please provide a rough estimate (if possible) of the percentage of parallel type and taper type ramp designs that your agency has designed or is currently designing.

Entrance ramps (Please fill in, if appropriate)

percent parallel type _____ percent taper type _____

Exit ramps (Please fill in, if appropriate)

percent parallel type _____ percent taper type _____

- C3) For the design of the acceleration lane length for an entrance ramp the AASHTO guide provides Table X-4 (see survey attachments). Does your agency utilize this table as shown?

Yes No

- C4) If you answered “No” to question C2), please markup Table X-4 to reflect your agency’s guidelines or attach to this survey a copy of the appropriate pages of your agency guideline.

- C5) For the design of the deceleration lane length for an exit ramp the AASHTO guide provides Table X-6 (see survey attachments). Does your agency utilize this table as shown?

Yes No

- C6) If you answered “No” to question C4), please markup Table X-6 to reflect your agency’s guidelines or attach to this survey a copy of the appropriate pages of your agency guideline.

Figure 2.1. New survey questionnaire (continued)

Questions D1) and D2) specifically refer to the design of loop ramps.

In the design of ramps AASHTO Table X-1 refers the designer to Table III-6 for the corresponding minimum radius for the design speed chosen. In the AASHTO text accompanying Table X-1 it may be interpreted that for a loop ramp connecting to a highway, the superelevation and minimum radius may be based on AASHTO Table III-17 (Tables III-6 and III-17 are included in the survey attachments).

D1) If your agency utilizes the AASHTO guide in loop ramp design does your agency utilize design values from Table III-6 or Table III-17? (Circle one)

Use Table III-6 Use Table III-17

D2) If your agency designs a loop ramp according to an agency design guide that differs from the AASHTO recommendations, please mark Table III-17 to reflect these changes or attach a copy of the appropriate pages from your agency's design guide.

Questions E1) to E3) relate to research efforts.

E1) Are you aware of any research currently being performed by your agency in the area of ramp design or an area related to ramp design? (Circle one)

Yes No

E2) If you answered "Yes" to question E1) please provide, if possible, a brief synopsis of this effort on the following page or attach any information to this survey that you feel may be useful.

E3) Please feel free to add any additional comments on the following page.

Again, thank you for participating in this very important survey. If you are available for some follow-up questions, please list below a phone number or email address where we may reach you.

Figure 2.1. New survey questionnaire (continued)

Highway Design Speed (mph)	30	40	50	60	65	70
Ramp Design Speed (mph)						
Upper Range (85%)	25	35	45	50	55	60
Middle Range (70%)	20	30	35	45	45	50
Lower Range (50%)	15	20	25	30	30	35
Corresponding Minimum Radius (ft)	See Table 111-6					

Source: 1990, AASHTO Table X-1, Guide values for ramp design speed as related to highway design speed

English Versions
AASHTO Table X-4

Highway		Acceleration Length, L (ft) for Entrance Curve Design Speed (mph)								
		Stop Condition	15	20	25	30	35	40	45	50
Design Speed (mph)	Speed Reached, V'a (mph)	And Initial Speed, V'a (mph)								
		0	14	18	22	26	30	36	40	44
30	23	190	—	—	—	—	—	—	—	—
40	31	380	320	250	220	140	—	—	—	—
50	39	760	700	630	580	500	380	160	—	—
60	47	1,170	1,120	1,070	1,000	910	800	590	400	170
70	53	1,590	1,540	1,500	1,410	1,330	1,230	1,010	830	580

SOURCE: AASHTO, 1990, *A Policy on Geometric Design of Highways and Streets*, Table X-4, Page 986
Minimum acceleration lengths for entrance terminals with flat grades of 2 percent or less

AASHTO Table X-5

Figure 2.1. New survey questionnaire (continued)

Highway		Deceleration Length, L (ft) for Design Speed of Exit Curve, V' (mph)								
		Stop Condition	15	20	25	30	35	40	45	50
Highway Design Speed, V (mph)	Average Running Speed, V'a (mph)	For Average Running Speed on Exit Curve, V'a (mph)								
		0	14	18	22	26	30	36	40	44
30	28	235	185	160	140	—	—	—	—	—
40	36	315	295	265	235	185	155	—	—	—
50	44	435	405	385	355	315	285	225	175	—
60	52	530	500	490	460	430	410	340	300	240
65	55	570	540	530	490	480	430	380	330	280
70	58	615	590	570	550	510	490	430	390	340

Source: AASHTO, 1990, *A Policy on Geometric Design of Highways and Streets*, Table X-6, page 991
Minimum deceleration lengths for exit terminals with flat grades of 2 percent or less

TABLE 1-5

Design (turning) speed, V (mph)	10	15	20	25	30	35	40
Side Friction Factor, f	0.38	0.32	0.27	0.23	0.20	0.18	0.16
Assumed minimum superelevation, e	0.00	0.00	0.02	0.04	0.06	0.08	0.09
Total $e + f$	0.38	0.32	0.29	0.27	0.26	0.26	0.25
Calculated minimum radius, R (ft)	18	47	92	154	231	314	426
Suggested curvature for — design:							
Radius — minimum (ft)	25	50	90	150	230	310	430
Degree of curve — maximum	—	—	64	38	25	18	13
Average running speed (mph)	10	14	18	22	26	30	34

Note: For design speeds of more than 40 mph, use values for open highway conditions

Source: 1990, AASHTO Table III- 17, pp. 197

Figure 2.1. New survey questionnaire (continued)

CHAPTER 3. DATA COLLECTION PLAN

The Chapter 1 literature review analysis indicated that there is no clear basis for the lower ramp design speed values (particularly 55 percent of freeway design speed) provided in the AASHTO and TxDOT guidelines. That analysis suggested that, in fact, the low values could be problematic. At the same time, the survey of current practice identified not only significant variability among design agencies regarding speed-change lane guidelines, but also almost no availability of operational ramp data. Accordingly, the collection of primary data describing ramp operations represents a way of resolving the questions regarding ramp design speed guidelines. The following describes a plan for that data collection effort.

DATA COLLECTION CONCEPTS

Two possible approaches might be used in collecting data enabling ramp design speed guideline evaluation. In one approach, the data collection effort could be designed to be sufficiently extensive to permit derivation of totally new guidelines, which could be compared with the existing numbers, thereby validating or suggesting revisions. This approach, while potentially satisfying, requires very extensive quantities of data. Another approach might concentrate data collection on those existing guideline elements that are most likely to be troublesome. This approach is attractive because it offers the opportunity to deal effectively with the most critical questions and requires far less effort. The plan developed here contains elements of both approaches.

A conceptual data collection plan is presented in matrix form in Table 3.1. Videotaping is considered the most desirable method of simultaneously capturing all potentially significant information. However, extensive video data-reduction experience indicates that this approach entails site setup, videotaping, and data reduction for each data set at each site and requires roughly two weeks. Thus, with roughly twelve months' data collection time available, twenty-four data sets can be studied and these would be ideally collected at twelve sites.

As indicated in the matrix, three ramp configurations, two ramp types, two design speeds, and two traffic volume levels are addressed. However, information obtained through the literature review and in the Chapter 2 survey of practice indicates all cells in this matrix are not equally important. Entrance ramp situations are possibly more problematic than exits, and those having short lengths or low design speeds are probably the worst cases. If these conceptual ideas are true, cells 1, 2, 9, 10, 17, and 18 might be considered highest priority efforts. However, each low design speed or short ramp case is matched to a high design speed or long ramp case and comparisons of operational data for these pairs are extremely important. Therefore, cells 3, 4, 11, 12, 19, and 20 are almost equally high priority because of the need for comparative information.

Table 3.1. Conceptual basic data collection plan

Ramp Configuration																							
Taper								Parallel								Loop							
Ramp Type								Ramp Type								Ramp Type							
Entrance				Exit				Entrance				Exit				Entrance				Exit			
Design Speed				Design Speed				Design Speed				Design Speed				Design Speed				Design Speed			
Low		High		Low		High		Low		High		Low		High		Low		High		Low		High	
Traffic Volume		Traffic Volume		Traffic Volume		Traffic Volume		Traffic Volume		Traffic Volume		Traffic Volume		Traffic Volume		Traffic Volume		Traffic Volume		Traffic Volume		Traffic Volume	
L	H	L	H	L	H	L	H	L	H	L	H	L	H	L	H	L	H	L	H	L	H	L	H
1	2	3	4	5	6	7	8	9	10	11	12	13	14	15	16	17	18	19	20	21	22	23	24

If the TxDOT-preferred ramp design is the taper rather than the parallel configuration, the need for the parallel configuration in the data collection plan might be questioned. Both ramp configurations are in use along Texas freeways; however, if future designs generally do not employ the parallel configuration, operational data probably need not be collected.

If all exit ramps and the parallel configuration were eliminated from the basic plan, eight cells would remain; with a budget of twenty-four data sets, three replicate sites could be acquired for each cell. Because replicate observations at multiple sites for each experimental condition are almost essential for understanding driver behavioral issues, this concept featuring replicates is highly desirable.

Table 3.2. Conceptual modified data collection plan

	Ramp Configuration															
	Taper								Loop							
	Ramp Type								Ramp Type							
	Entrance				Exit				Entrance				Exit			
	Design Speed				Design Speed				Design Speed				Design Speed			
	Low		High		Low		High		Low		High		Low		High	
	Traffic Volume		Traffic Volume		Traffic Volume		Traffic Volume		Traffic Volume		Traffic Volume		Traffic Volume		Traffic Volume	
	Ramp Configuration															
	1	2	3	4					5	6	7	8				
	R1	R1	R1	R1					R1	R1	R1	R1				
Replicates	R2	R2	R2	R2				R2	R2	R2	R2					
	R3	R3	R3	R3				R3	R3	R3	R3					

SITE SELECTION CONSIDERATIONS

Candidate video data collection sites must include the desired geometric features, appropriate traffic demands, and an elevated observation position, ideally a tall building. Data for several such sites in Houston and Austin have been collected, analyzed, and will become part of the study database. However, at least twenty additional sites will be required to fill the cells of the modified plan (including replicates). Potential sites in San Antonio, Dallas-Fort Worth, El Paso, Corpus Christi, and Houston will be examined. Personnel with the traffic control centers in San Antonio and Houston indicate a few sites currently under video surveillance may be appropriate. However, owing to camera positions and geometric ramp features, the number of such locations is apparently quite limited.

The Chapter 2 state-of-practice review indicated an apparent need for discrimination between rural and urban design criteria. Although less stringent criteria for rural design might be sensible, designing this data collection effort to meet that need does not seem appropriate. User costs resulting from ramp operational and safety deficiencies are much greater in urban areas because of larger traffic demands. Therefore, concentration of the research effort on urban locations seems highly desirable. Accordingly, rural data collection sites are not recommended as high-priority choices.

DEPENDENT VARIABLES

All quantities presented in the basic and modified data matrices (from ramp configuration to traffic volume) are potential independent or predictor variables. Additionally, specific characterizations of geometric features at each data collection site, including lane widths, curve radii, lane lengths, grades, and other elements, are potential independent or predictor variables. Dependent or predicted variables will likely include ramp vehicle position, speed, acceleration, and interaction with freeway vehicles. The 1994 *Highway Capacity Manual* (HCM), Chapter 5, deals with freeway entrance and exit ramps; it defines a freeway influence area in the vicinity of ramps as including the two right-most freeway main lanes and extending roughly 457 m up or downstream from the ramp gore. A similar definition has been used in previous ramp studies by the research team and will be tentatively adopted here. Within the influence area, freeway flow and density will be measured using short, multiple-minute time intervals and space mean speed will be inferred from the flow and density. Position/speed time histories of ramp vehicles will be determined. These data can be used both to derive predictive ramp vehicle trajectory models and to compare driver behavior on high- and low-design-speed ramps.

ACCIDENT HISTORY

As indicated in the Chapter 2 survey information, most agencies evaluate speed-change facilities using primarily accident data. Certainly, accident experience is an indicator of geometric design problems and must be included in these data collection efforts. Use of accident data as the primary evaluation measure in this study would almost certainly prove to

be problematic owing to the reported level of detail regarding specific location, nature, and cause of most accidents. Additionally, state law does not require reporting of minor property damage (only accidents), and reports of many major accidents are never entered into the appropriate database.

Recognizing the problems associated with accident data, we nonetheless regard safety as an essential evaluation tool that should be included. Thus, accident data will be requested for all sites involved in the operational data collection effort. Accident histories for all sites will become another dependent or predicted variable in terms of this experiment. Relatively complete accident history data will permit both direct comparisons between high- and low-design-speed sites and predictive model development.

Expansion of the accident history analysis to include more ramp cases than are included in the operational data collection would be very desirable. Past experiences with available accident databases indicate this expansion may not be fruitful owing to a lack of precise accident report data. However, the research team intends to make a concerted effort to extend the analysis using accident history information.

SPECIAL LOOP RAMP CONSIDERATIONS

In the context of this discussion, loop ramps are characterized as any ramp where horizontal curvature is a dominant, possibly speed-limiting, element. Such geometric features commonly occur in directional and cloverleaf interchanges, as well as in trumpet and Y configurations. Sites with elevated observation positions enabling high-level video data collection, as envisioned for taper type ramps, may not be possible. If such sites must be included, chase car or floating car methods may be substituted for video-based ramp vehicle speed time history. Observer and/or infrared sensor technology might be substituted for video-based freeway-flow data. Such substitutions for preferable video data collection may require special scheduling and analysis adaptations. Special care must also be taken in matching pairs of high- and low-design-speed loop ramps, such that they conform in terms of geometric and driver behavioral elements. For example, driver behavior in a low-design-speed loop of a rural cloverleaf interchange might differ so substantially from driver behavior in a high-design-speed urban directional interchange that comparisons of such a ramp pair might be problematic.

SUMMARY

Conceptual basic and modified data collection plans have been presented featuring operational and accident history elements. The plans attempt to match pairs of low- and high-design-speed ramps so as to permit direct operational and safety comparisons. If adequate accident history data can be procured, the safety comparative analysis can be extended to cover additional cases. The preferred method of operational data collection is high-level video, though this method can be supplemented or replaced by other, less robust techniques, if necessary.

REFERENCES

1. American Association of State Highway and Transportation Officials (AASHTO), *A Policy on Geometric Design of Highways and Streets*, Washington, D.C., 1994.
2. C. E. Lee, Class Notes, CE 391M, Advanced Geometric Design, The University of Texas at Austin, spring, 1993.
3. William R. McShane and Roger P. Roess, *Traffic Engineering*, Prentice Hall, Englewood Cliffs, NJ, 1990.
4. G. Johansson and K. Rumar, "Drivers' Brake Reaction Times," *Human Factors*, Vol. 13, No. 1, February 1971, pp. 23–27.
5. State Department of Highways and Public Transportation (SDHPT), *Highway Design Division Operations and Procedures Manual*, SDHPT, February 20, 1987.
6. American Association of State Highway Officials (AASHO), *A Policy on Geometric Design of Rural Highways*, Washington, D.C., 1965.
7. D. W. Loutzenheiser, *Speed-Change Rates of Passenger Vehicles*, Highway Research Board, 1938, pp. 90–99.
8. C. W. Prisk, *Passing Practices on Rural Highways*, Highway Research Board Proceedings, 1941.
9. *Speed-Change Lanes Final Report*, National Cooperative Highway Research Program (NCHRP), Transportation Research Board (TRB), National Research Council (NRC), Project 3-35, December 1989.
10. E. E. Wilson, *Deceleration Distances for High-Speed Vehicles*, Highway Research Board Proceedings, 1940, pp. 393–398.

11. John Bealey, *Acceleration and Deceleration Characteristics of Private Passenger Vehicles*, Highway Research Board Proceedings, 1938, pp. 81–89.
12. *Traffic Performance at Urban Street Intersections* — Technical Report No. 1, Yale Bureau of Highway Traffic, 1947.
13. P. L. Olson, D. E. Cleveland, P. S. Fancher, L. P. Kostyniuk, and L. W. Schneider, *Parameters Affecting Stopping Sight Distance*, NCHRP Report 270, TRB, NRC, June 1984.
14. W. S. Homburger, L. E. Keefer, and W. R. McGraft, *Transportation and Traffic Engineering Handbook*, Second Edition, Institute of Transportation Engineers, Prentice-Hall, Inc., Englewood Cliffs, NJ, 1982.
15. J. N. Hooker, *Optimal Driving for Single-Vehicle Fuel Economy*, Transportation Research, Part A, Volume 22A, Number 3, May 1988, pp. 183–201.
16. AASHTO, *A Policy on Design of Urban Highways and Arterial Streets*, Washington, D.C., 1973.
17. D. E. Hearne and J. E. Clark, “Acceleration Characteristics of Late-Model Automobiles,” *Transportation Research Record*, 1983.
18. R. L. Stuard, *Acceleration Characteristics of a Passenger Car at a Stop-Control Intersection*, master’s thesis, The University of Texas at Austin, 1986.
19. J. D. Hayword, W. E. Fusetti, and J. Michele, *Improved Operations for Ramps and Speed-Change Lanes — Executive Summary*. Report No. FHWA/RD-81/031, August 1981.
20. Harold Lunenfeld, “Human Factors Associated with Interchange Design Features,” *Transportation Research Record*, No. 1385, pp. 84–89.

21. J. M. Twomey, M. L. Heckman, J. C. Hayward, and R. J. Zuk, "Accidents and Safety Associated with Interchanges," *Transportation Research Record*, No. 1385, pp. 100–105.
22. D. W. Harwood and J. M. Mason Jr., "Ramp/Mainline Speed Relationships and Design Considerations," *Transportation Research Record*, No. 1385, pp. 121–125.
23. Frank J. Koepke, "Ramp Exit/Entrance Design — Taper Versus Parallel and Critical Dimensions," *Transportation Research Record*, No. 1385, pp. 126–132.
24. J. A. Keller, "Interchange Ramp Geometrics — Alignment and Superelevation Design," *Transportation Research Record*, No. 1385, pp. 148–154.
25. C. W. Plummer Jr., Martin T. Pietrucha, and J. M. Mason Jr., *Design of Interchange At-Grade Ramp Terminals*, Transportation Research Record, No. 1385, pp. 155–161.
26. J. A. Cirillo, S. K. Dietz, and R. L. Beatty, *Analysis and Modeling of Relationships Between Accidents and the Geometric and Traffic Characteristics of the Interstate System*, Office of Research and Development, Traffic Systems Division, U.S. Department of Transportation/Federal Highway Administration/BPR.
27. Charles M. Noble, *Thoughts on Highway Design Research as Related to Safety of Vehicle Operation*, Highway Research Board, 1937, pp. 242–253.
28. R. M. Michaels and J. Fazio, "Driver Behavior Model of Merging," TRB Report 1213, *Human Performance and Highway Visibility, Design, Safety, and Methods*, pp. 4–10.
29. *Controlled Access Expressways in Urban Areas — A Symposium*, Highway Research Board Bulletin No. 25, Washington, D.C., July 1950.
30. D. W. Loutzenheiser, *Proposed Design Standards for Interregional Highways*, Highway Research Board, 1944, pp. 105–126.

31. P. N. Seneviratne and M. N. Islam, "Speed Estimates for Roadway Design and Traffic Control," *Transportation Research Record*, No. 1375, Safety Research: Enforcement, Speed, Older Drivers, and Pedestrians, pp. 37–43.
32. M. M. Davis and K. M. Williams, *Vehicle Operating Characteristics on Outer Loop Deceleration Lanes of Interchanges*, Department of Civil Engineering, University of Toronto, Toronto 5, Ontario, O.J.H.R.P. No. 43, March 1968.
33. J. G. Yates, *Relationship Between Curvature and Accident Experience on Loop and Outer Connection Ramps*, Highway Research Record 312, NRC, Washington, D.C., 1970, pp. 64–75.
34. R. A. Lundy, *The Effect of Ramp Type and Geometry on Accidents*, Highway Research Record 163, NRC, Washington, D.C., 1967, pp. 80–117.
35. R. Ervin, M. Barnes, C. MacAdam, and R. Scott, *Impact of Special Geometric Features on Truck Operations at Interchanges*, Transportation Research Institute, University of Michigan, Ann Arbor, 1985.
36. J. A. Cirillo, *Interstate System Accident Research Study II*, Interim Report, Part I, Highway Research Record 188, National Research Council, Washington, D.C., August 1968, pp. 71–75.
37. *Special Report 209: Highway Capacity Manual*, TRB, NRC, Washington, D.C., 1990.
38. J. C. Glennon, T. R. Neuman, and J. E. Leish, *Safety and Operational Considerations for Design of Rural Highway Curves*, Report RD-36/035, FHWA, USDOT, 1985.