

Cave Gating Criteria

William R. Elliott, Ph.D.
Cave Biologist, Resource Science Division
Missouri Department of Conservation

Rationale

Poor cave gates can harm wildlife and cave resources. There are many reasons for not gating a cave, and cave gating is not automatically recommended by the Missouri Department of Conservation (MDC). In Missouri private cave owners are generally protected by law from legal liability for injuries to cave visitors, unless it is a commercial show cave. Cave gating is a technical subject that requires knowledge and experience; for example, it cannot be done properly by a general welding contractor without providing specifications, a design and on-site supervision by an experienced cave gater. Knowledge of the cave's ecology, especially bats, is necessary before a gate is considered. MDC assists cave owners in cave gating, but first a decision guide must be followed (below).

Cave Gate Types

Depending on the needs of the cave, the type of entrance, bats and other wildlife, the design could specify a full gate, half gate, chute gate, cupola gate, vertical bar fence or no gate at all (see illustrations). Caves that have lost their bats may be recolonized with proper gates. Except for vertical bar fences, all gates must have horizontal bars to admit bats, as they cannot fly between vertical bars. Full or constricted gates are not recommended for maternity colonies of Gray bats. Some bat caves that may need a gate for protection are not feasible to gate for certain physical reasons. Many caves that are feasible to gate do not need to be gated because other modes of protection may work better.

Appendix III Design A

These plans are provided courtesy of the American Cave Conservation Association and are revised annually. Contact the ACCA for current construction specifications or for consultation on special needs (see Appendix II).

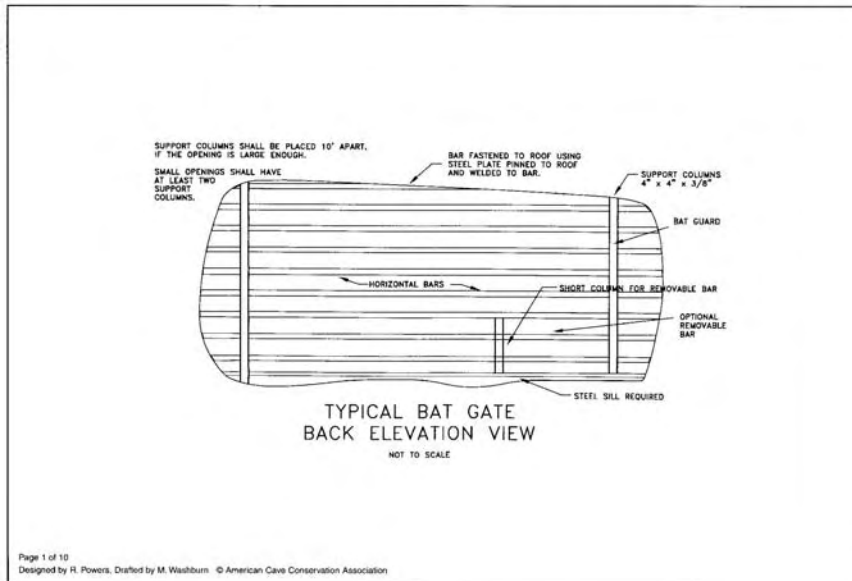

Proper design for a "full" bat gate by ACCA's Roy Powers. From BCI's *Bats and Mines*.

Who is Qualified?

Bill Elliott is the cave and karst coordinator for MDC, and all MDC cave studies and cave gating projects should go through him for scoping, design and approval. Bill has many years of experience in cave ecology, cave management, and cave gating. A few MDC personnel, who are trained in the latest cave gating methods, can work with Bill to build gates, but are not experienced in cave gate design.

Three experts are Roy Powers, Jr., of Duffield, Virginia; Jim Kaufmann, Newburg, MO; and Jim Nieland, U.S. Forest Service, Mount St. Helens, Washington. Mr. Powers is an engineer and cave ecologist who has designed, built, or supervised, more than 600 cave gates. Roy is the leading innovator of bat-friendly cave and mine gates, sometimes called "air-flow bat gates", for the American Cave Conservation Association (ACCA). ACCA is a nonprofit organization based in the city of Horse Cave, Kentucky, with expertise in cave conservation, restoration, gating and education. ACCA's designs were adopted by Bat Conservation International (BCI) and many government agencies, and have become the industry standard, as specified in the publication "Bats and Mines" by BCI (see Recommended Reading below). Jim Kaufmann has built many cave gates, and he contracts with several agencies. Jim Nieland is a cave specialist for the U.S. Forest Service who builds cave gates and teaches cave gating.

Appendix III Design A

These plans are provided courtesy of the American Cave Conservation Association and are revised annually. Contact the ACCA for current construction specifications or for consultation on special needs (see Appendix II).

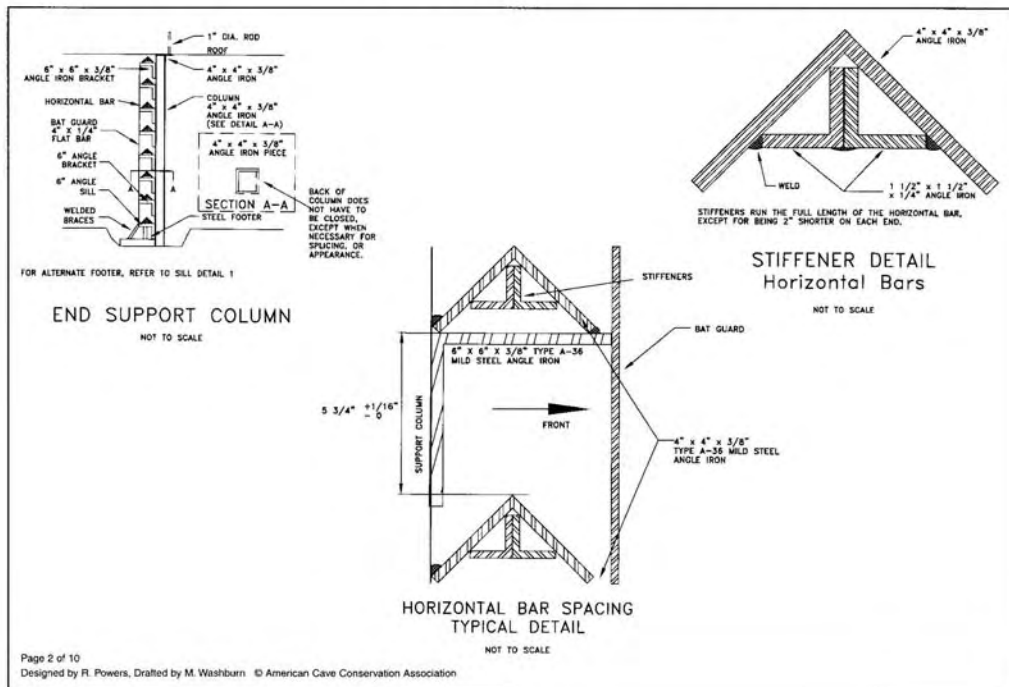

ACCA and BCI, in cooperation with the U.S. Fish & Wildlife Service, U.S. Forest Service, and many agencies, have taught numerous, regional, cave-gating workshops to demonstrate the proper decision-making process, design, and construction techniques for ecologically sound cave gates. These gates have resulted in significant protection and increases of colonies of endangered bats, such as Grays,

Indianas, and others. Protection of other irreplaceable cave resources is another benefit of properly built gates. Major clients include U.S. Army Corps of Engineers, Bureau of Land Management, U.S. Forest Service, National Park Service, and numerous state and local agencies.

Specifications

Specifications vary for different gate styles (see "Bats and Mines" by BCI). Gates are usually made of mild steel. "Modified steel" has more carbon, is stronger and stiffer, and may cost only a little more than mild steel. Stainless and manganal steels are optional for gates in corrosive environments, but they are several times more expensive than mild steel and are unnecessary in most applications. Some special designs are more resistant to hacksaws.

A good gate is made mostly of 1/2" thick angle iron, stronger than the common 1/4". The sill (bottom of the gate) is of 6 x 6" angle, usually set over a mat of expanded metal, which prevents vandals from tunneling under the gate. The pins are welded to the gate via large hangers made of 6 x 6" angle, providing more strength than welding the pins directly to the gate. The horizontal bars and columns usually are made of 4 x 4" angle iron strengthened with T-bar stiffeners welded inside from 1 1/2 x 1 1/2 x 1/4" angle; this resists bending from hydraulic jacks. Sometimes we use concrete and re-bar to stiffen the bars. The horizontal bars are spaced at 5 3/4" between bars on hangers made from 6 x 6" angle. The bars are spaced using spacing gauges that can be knocked out after the bars are welded to the hangers. Gates built by novices is that the bars may be irregularly spaced, which can discourage bats and invite humans to crawl through. The drawings in this document detail bars and stiffeners.

To finish the gate, a "bat guard" is welded on the front of the bars at each column, to prevent bats from tearing their wings on hangers. A removable bar with a hidden latch and shrouded (boxed-in) lock is now standard, and is more resistant than a hinged door is to vandals with tools. We normally use padlocks with brass or coated parts to resist rust. Combination locks and chains around the gate should be avoided because they are more vulnerable to bolt cutters and hammers. However, a well-protected, heavy-duty combination lock may be useful on a cave that is monitored often; the combination should be changed routinely.

Many gates are not coated, but any coatings that are applied should be brushed on, not sprayed, to avoid volatiles from entering the cave. Cave gates usually are constructed during a season when bats are not vulnerable, or when air is flowing out of the entrance, thus removing welding fume from the cave. If airflow is not adequate, an air curtain should be put up to keep fumes out of the cave. Ventilation fans may be needed for worker safety (see Elliott, 1995).

Limited space does not allow a full discussion here of the many construction techniques that have been developed for cave gating. Please see Recommended Reading for helpful literature.

Estimates

Jim Nieland developed some cost estimation methods based on past projects. In 2002 mild steel was estimated at about \$8.88 per sq. ft. of standard gate. The steel weighs about 22.2 lb. per sq. ft., and the average cost per lb. was \$.42 with a range of \$.38-.50. Prices have increased since then. In 2005 we paid \$.36 per lb. on a low bid.

Gates built by volunteers may cost as little as \$25 per sq. ft., materials included. Gates built by agency personnel may cost about \$30 per sq. ft., and by contractors up \$50 per sq. ft. or more unless the labor

and materials are provided. Many projects include both paid and volunteer labor, so the cost may vary between the above limits. The above examples do not include administrative costs and staff time, which may send the total cost above \$60 per sq. ft.

What to Avoid

A few rules of thumb can be followed. Natural entrances should not be sealed because that would change the natural meteorology of the cave and access by native wildlife. Opening a long-sealed cave also can cause problems for the cave unless some means of protection is devised. Gates should not be made of re-bar (it is much too weak). Chain link fences are easily violated. Do not construct any raised footings, stone work, or concrete walls on the floor or around a gate because they can hinder air exchange and cause a change in temperature at the bats' favorite roosts. Gates should be tailored for the wildlife inhabiting the cave. A cave gate is not a substitute for good land management, but a last resort.



The world's second largest cave gate, Great Spirit Cave, Pulaski County, Missouri. The half gate weighs 18 tons and is 101 ft. wide and up to 14 ft. tall. Completed in October 2002, it protects endangered Gray and Indiana bats and multiple resources. By Mike Slay.



The “chute gate” at Tumbling Creek Cave, Taney County, Missouri. The rectangular, expanded-metal chute allows maternal Gray bats to access the cave. The colony increased after the gate was built, April 2004. By Bill Elliott.

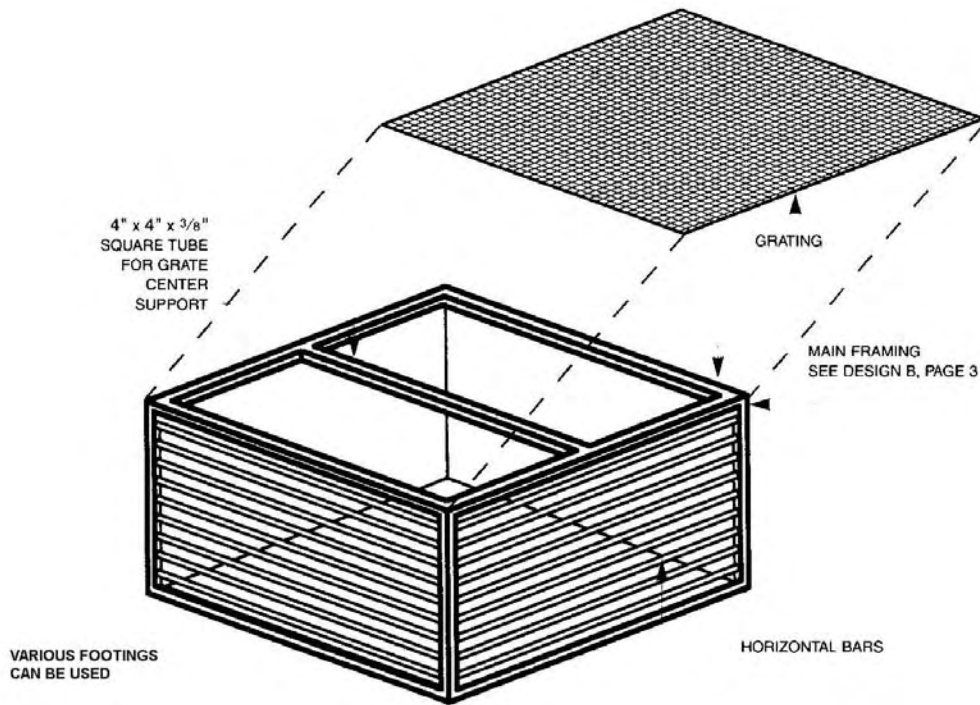

A cupola, or cage gate (from *Bats and Mines*) is used on some sinkhole entrances. Some are built on a slope with an beveled bottom.



A 10-foot-high, vertical bar fence around a pit entrance in Missouri. The access door is temporarily open.
By Jim Kaufmann and Kenny Sherrill.

Recommended Reading

- Elliott, William R. 1996. The evolution of cave gating: How the philosophy and technology have changed. *American Caves*, 9(2):9-15.
A review of cave gating innovations and the decisions that precede a cave gate.
- Elliott, William R., and Jonathan B. Beard. 2000. Cave restoration. *Missouri Conservationist*, 61(10):14-16.
Discusses the gating of Little Scott Cave and how it prevented vandalism.
- Missouri Revised Statutes. 2004. Chapter 537, Torts and Actions for Damages, Sections 537.345-348.
<http://www.moga.state.mo.us/statutes/statutes.htm>
- Kennedy, Jim. 2006. On cave gates. Pp. 147-165 in Hildreth-Werker, V., and J. Werker (eds.). *Cave Conservation and Restoration*. National Speleological Society. 600 pp.
- Nieland, Jim. Bat gate construction, on-site coordination, and work. 2004. Proceedings of Bat Gate Design: A Technical Interactive Forum, March 4-6, 2002, Austin, Texas. <http://www.mcrcc.osmre.gov/bats/> (see link to Bat Gate Design Forum).
The best all-around article on how to do a cave gate.
- Powers, Roy D., Jr. 2004. The angle-iron bat gate. Proceedings of Bat Gate Design: A Technical Interactive Forum, March 4-6, 2002, Austin, Texas. <http://www.mcrcc.osmre.gov/bats/> (see link to Bat Gate Design Forum). See many other papers on gating at the same website.
- Taylor, Daniel A.R., and Merlin D. Tuttle. 1998. *Bats and Mines*. Resource Publication No. 3, Bat Conservation International, Austin, Texas. 50 pp.
Information on bat ecology and 13 pages of engineering drawings for designing and building air-flow bat gates. Now online at <http://www.batcon.org/home/index.asp?idPage=53&idSubPage=87>
- Vories, K.C., D. Throgmorton, and A. Harrington (eds.). 2004. Proceedings of Bat Gate Design: A Technical Interactive Forum, March 4-6, 2002, Austin, Texas. U.S. Department of Interior, Office of Surface Mining, Alton, Illinois and Coal Research Center, Southern Illinois University, Carbondale, Illinois. 434 pp. <http://www.mcrcc.osmre.gov/bats/>

Cave Gating Decision Guide

1. Are there poor reasons not to gate the cave? For example,

- Purely aesthetic objections to a gate while the cave's resources are being degraded anyway.
- It may "start a trend" towards too much gating.
- Because a few people consider themselves above the rules and may threaten the gate.

Score no points for any poor reasons not to gate.

2. Are there poor reasons for gating the cave? For example,

- For fear of liability, which probably is nonexistent. Cave owners are protected by law in Missouri.
- For administrative convenience (instead of having a comprehensive conservation program).
- To keep wild animals or competing explorers out.

Score no points for any poor reasons to gate.

3. Are there good reasons not to gate the cave? For example,

- The gate will not comply with current ACCA and BCI standards.
- A vigilant owner or manager lives nearby.
- Other controls can be used—road gates, signs, surveillance.
- Visitors probably will comply with a good permit system.
- Experts are opposed to the gate.
- The cave gaters are inexperienced and overconfident.
- No one will commit to checking and maintaining the gate.
- Technical reasons: The entrance is too small for a proper gate (e.g., half gate for Gray bat maternity colony), or the environment or budget will not allow a good design.

Score one point each **against** gating if any good reasons against gating hold true.

4. Are there good reasons to gate the cave?

- The cave is hazardous to casual visitors and no other controls (permits and signs) are adequate.
- Endangered species inhabit the cave and can be bolstered by protection.
- The cave is a target for vandals, looters and trespassers. A "better clientele" is needed.
- The cave has high value, is threatened, and it can best be studied and appreciated with a good permit system combined with a gate.

Score one point each **for** gating if any good reasons hold true.

Final results: Add up the points for and against gating, and determine which seems more important. Other criteria may have to be considered.

This document is in the public domain, and it may be used, without alterations, for educational purposes, although its audience primarily is in Missouri. — William R. Elliott, 9/8/06